

SD card real time data logger

DISSOLVED OXYGEN METER

Model : DO-5512SD



Your purchase of this DISSOLVED OXYGEN METER with SD CARD DATA LOGGER marks a step forward for you into the field of precision measurement. Although this meter a complex and delicate instrument, its durable structure will allow many years of use if proper operating techniques are developed. Please read the following instructions carefully and always keep this manual within easy reach.



OPERATION MANUAL

TABLE OF CONTENTS

1. FEATURES.....	1
2. SPECIFICATIONS.....	2
3. FRONT PANEL DESCRIPTION.....	5
4. DO (Dissolved Oxygen) MEASURING and CALIBRATION PROCEDURE.....	7
4-1 Dissolved Oxygen measurement.....	7
4-2 Calibration.....	10
4-3 Probe maintenance.....	11
5. OTHER FUNCTION.....	13
5-1 Data Hold.....	13
5-2 Record (Max./ Min. reading).....	13
5-3 LCD Backlight ON/OFF.....	14
6. DATALOGGER.....	14
6-1 Preparation before execute datalogger function.....	14
6-2 Auto Datalogger (Set sampling time \geq 1 second).....	15
6-3 Manual Datalogger (Set sampling time = 0 second).....	16
6-4 Check time information.....	17
6-5 Check sampling time information.....	17
6-6 SD Card Data structure.....	17
7. Saving data from the SD card to the computer.....	19
8. ADVANCED SETTING.....	21
9. POWER SUPPLY from DC ADAPTER.....	28
10. BATTERY REPLACEMENT.....	28
11. SYSTEM RESET.....	28
12. RS232 PC SERIAL INTERFACE.....	29
13. OPTIONAL ACCESSORIES.....	30
14. PATENT.....	31

1. FEATURES

- * Precision Dissolved Oxygen measurement
- * Dissolved oxygen : 0 to 20.0 mg/L.
- * Dissolved oxygen meter use the polar graphic type oxygen probe with temperature sensor, high precision measurement for Dissolved Oxygen (DO) and temperature measurement.
- * Heavy duty dissolved oxygen probe, probe head can connect with BOD bottle.
- * DO use the automatic Temp. compensation.
- * DO meter build in " % SALT " & " Mountain Height " compensation value adjustment.
- * Separate probe, easy for operation of different measurement environment.
- * Real time SD memory card Datalogger, it Built-in Clock and Calendar, real time data recorder , sampling time set from 1 sec to 8 hour 59 min. 59 sec.
- * Manual datalogger is available (set the sampling time to 0), during execute the manual datalogger function, it can set the different position (location) No. (position 1 to position 99).
- * Innovation and easy operation, computer is not need to setup extra software, after execute datalogger, just take away the SD card from the meter and plug in the SD card into the computer, it can down load the all the measured value with the time information (year/month/date/ hour/minute/second) to the Excel directly, then user can make the further data or graphic analysis by themselves.
- * SD card capacity : 1 GB to 16 GB.
- * LCD with green light backlight, easy reading.
- * Can default auto power off or manual power off.
- * Data hold, record max. and min. reading.
- * Microcomputer circuit, high accuracy.
- * Power by UM3/AA (1.5 V) x 6 batteries or DC 9V adapter.
- * RS232/USB PC COMPUTER interface.

- * Wide applications: water conditioning, aquariums, beverage, fish hatcheries, food processing, photography, laboratory, paper industry, plating industry, quality control, school & college, water conditioning.

2. SPECIFICATIONS

Circuit	Custom one-chip of microprocessor LSI circuit.	
Display	LCD size : 52 mm x 38 mm LCD with green backlight (ON/OFF).	
Measurement	Dissolved Oxygen Air oxygen (for reference only)	
Measurement & Range	Dissolved Oxygen	0 to 20.0 mg/L (liter).
	Oxygen in Air	0 to 100.0 %.
	Temperature	0 to 50 °C .
Resolution	Dissolved Oxygen	0.1 mg/L.
	Oxygen in Air	0.1 % O ₂ .
	Temperature	0.1 °C .
Accuracy (23± 5 °C)	Dissolved Oxygen	± 0.4 mg/L.
	Oxygen in Air	± 0.7% O ₂ .
	Temperature	± 0.8 °C/1.5 °F.
Probe Compensation & Adj.	Temperature	0 to 50 °C , Automatic
	Salt	0 to 50 % Salt
	Height (M. T.)	0 to 8900 meter
Datalogger Sampling Time Setting range	Auto	1 sec to 8 hour 59 min. 59 sec. <i>@ Sampling time can set to 1 second, but memory data may loss.</i>
	Manual	Push the data logger button once will save data one time. <i>@ Set the sampling time to 0 second.</i> <i>@ Manual mode, can also select the 1 to 99 position (Location) no.</i>

Oxygen Probe	The polarographic type oxygen probe with temp. sensor.
Memory Card	SD memory card. 1 GB to 16 GB.
Advanced setting	<ul style="list-style-type: none"> * SD memory card Format * Set clock time (Year/Month/Date, Hour/Minute/ Second) * Set sampling time * Auto power OFF management * Set beep Sound ON/OFF * Decimal point of SD card setting * Set temperature unit to °C or °F * Set DO salt% compensation value * Set DO height (meter) compensation value * Set DO height (feet) compensation value
Data Hold	Freeze the display reading.
Memory Recall	Maximum & Minimum value.
Sampling Time of Display	Approx. 1 second.
Data Output	RS 232/USB PC computer interface. <ul style="list-style-type: none"> * <i>Connect the optional RS232 cable UPCB-02 will get the RS232 plug.</i> * <i>Connect the optional USB cable USB-01 will get the USB plug.</i>
Operating Temperature	0 to 50 °C.
Operating Humidity	Less than 85% R.H.
Power Supply	* Alkaline or heavy duty DC 1.5 V battery (UM3, AA) x 6 PCs, or equivalent.
	* DC 9V adapter input. (AC/DC power adapter is optional).

Power Current	Normal operation (w/o SD card save data and LCD Backlight is OFF) : <i>Approx. DC 14 mA.</i>	
	When SD card save the data and LCD Backlight is OFF) : <i>Approx. DC 37 mA.</i>	
	* <i>If LCD backlight on, the power consumption will increase approx. 12 mA.</i>	
Weight	Meter	489 g/1.08 LB.
	Probe	335 g/0.74 LB
Dimension	Meter	177 x 68 x 45 mm (7.0 x 2.7x 1.9 inch)
	Probe	190 mm x 28 mm Dia. (7.5" x 1.1" Dia.)
Accessories Included	* Oxygen probe (OXPB-11)..... 1 PC. * Hard carrying case (CA-06)..... 1 PC. * Operation manual..... 1 PC. * Spare Probe head with Diaphragm OXHD-04.....2 set * Probe-filling Electrolyte OXEL-03.....1 set	
Optional probe and accessories	* Oxygen probe..... OXPB-11 * Spare Probe head with Diaphragm set.....OXHD-04 * Probe-filling Electrolyte..... OXEL-03 * RS232 cable.....UPCB-02 * USB cable..... USB-01 * Data Acquisition softwareSW-U801-WIN * AC to DC 9V adapter	

@ Above specification tests under the environment RF Field Strength less than 3 V/M & frequency less than 30 MHz only.

3. FRONT PANEL DESCRIPTION

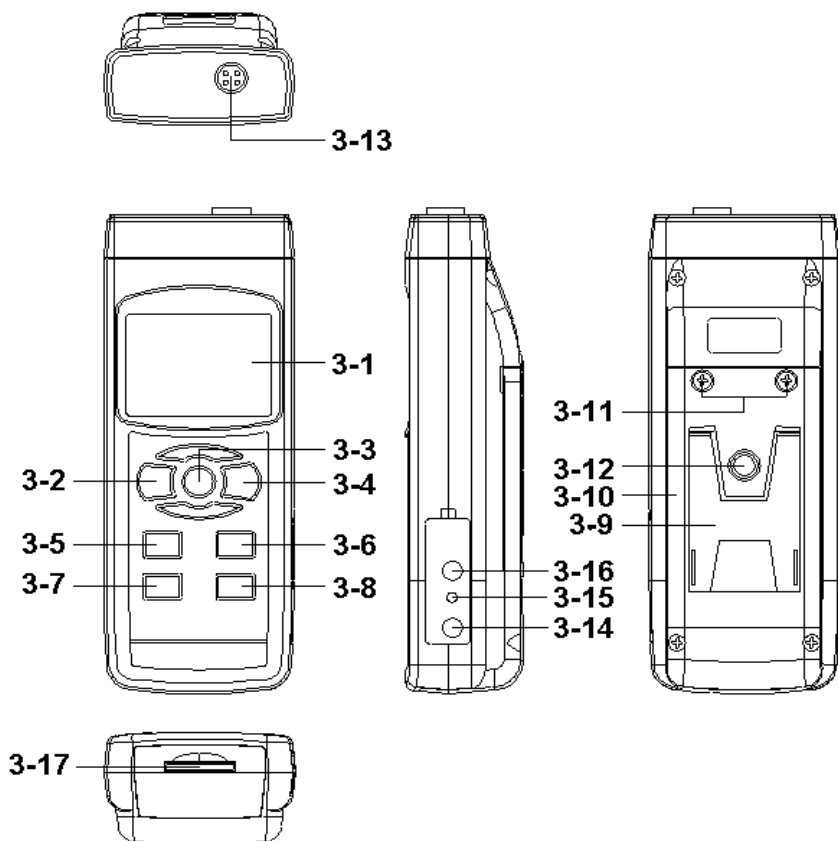

- 3-1 Display
- 3-2 Power Button (Backlight Button)
- 3-3 Hold Button (ESC Button)
- 3-4 REC Button (Enter Button)
- 3-5 ▲ Button
- 3-6 ▼ Button (Function Button)
- 3-7 Time Button
- 3-8 Logger Button (SET Button, Sampling check)
- 3-9 Stand
- 3-10 Battery Compartment/Cover
- 3-11 Battery Cover Screw
- 3-12 Tripod Fix Nut
- 3-13 DO Probe Socket
- 3-14 DC 9V Power Adapter Input Socket
- 3-15 Reset Button
- 3-16 RS-232 Output Terminal
- 3-17 SD card socket

4. DO (Dissolved Oxygen) MEASURING and CALIBRATION PROCEDURE

4-1 Dissolved Oxygen measurement

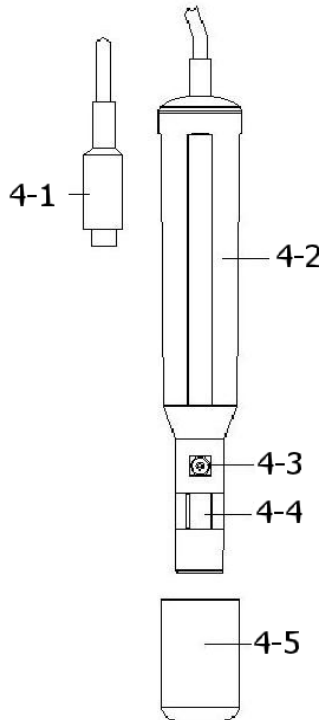

Fig. 2

- 1) Prepare the Oxygen Probe (standard probe, DOPB-11), install the " Probe Plug " (4-1, Fig. 2) into the " DO Socket " (3-13, Fig. 1).
- 2) Power on the meter by pressing " Power Button " (3-2, Fig. 1) once.



Calibration at first !

If it is the first time to use the Dissolved Oxygen meter or after a certain period to use the meter again, then it should to execute the calibration procedures at the first. For the measurement precisely consideration, it recommend to make the calibration before each measurement. Calibration procedure, refer to chapter 4-2, page 10.

- 4) a. Immersed the probe to a depth at least 10 cm of the measured liquid in order for the probe to be influenced by the temperature & automatic temperature compensation to take place.
b. As for the thermal equilibrium to occur between the probe & the measurement sample must be allowed to pass, which usually amounts to a few minutes if the Temp. difference between the two is only several Celsius degrees.
- 5) a. In order to measure the dissolved oxygen content in any given liquid, it is sufficient to immerse the tip of the probe in the solution, making sure that velocity of the liquid coming into contact with the probe is at least 0.2 - 0.3 m/s or to shake the probe.
b. During laboratory measurements, the use of a magnetic agitator to ensure a certain velocity in the fluid is recommended. In this way, errors due to the diffusion of the oxygen present in the air in the solution are reduced to a minimum.

- 6) Display will show the Dissolved Oxygen values (mg/L)
at the same time the bottom display will show the Temp.
value of the measured solution.
- 7) Rinsed the probe accurately with normal tap water after
each series of measurement.

Oxygen in the air

During the DO measurement, press the " Function Button "
(3-6, Fig. 1) once, the display unit will show " %O2 "
instead of " mg/L " , it show the air Oxygen value for
reference.

*@ Press the " Function Button " once again, the Display
unit will return to " mg/L " .*

Change the Temp. unit to °F

If intend to change the Temp. unit from °C to °F,
please refer to chapter 8-7, page 25.

"% Salt" compensation value adjustment

If intend to change the % Salt compensation value,
refer chapter 9-8, page 26.

"Height" compensation value adjustment

If intend to change the Height compensation value,
refer to chapter 8-9, 8-10, page 26 page 27.

4-2 Calibration

- 1) Install the " Probe Plug " (4-1, Fig. 2) into the " DO Socket " (3-13, Fig. 1).
- 2) Power on the meter by pressing " Power Button " (3-2, Fig. 1) once.
Press the " Function Button " (3-6, Fig. 1) once, to let Display unit will show " %O2 " instead of " mg/L ".
- 3) **Wait for approx. 5 minutes at least until the display reading values become stable & no fluctuation.**
- 4) Use the two fingers to press the " REC Button " (3-4, Fig 1) and HOLD Button " (3-3, Fig. 1) at the same time, the display will show the following screen as example, release the both fingers.

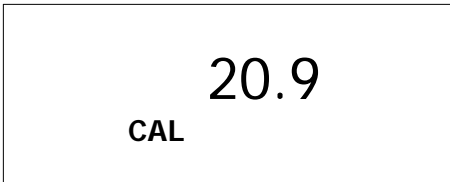

- 5) Press the " Enter Button " , the Display value will count from 30 to 0, then return to normal measuring screen and finish the calibration procedures. The complete calibration procedures will take 30 seconds approximately.

Press the " Function Button " (3-6, Fig. 1) once, to let Display unit to return " mg/L ".

Calibration Consideration :

- a. As the oxygen in air is 20.9 % typically, so use the environment air O2 value for quick & precise calibration.***
- b. Please process calibration procedures under wide and ventilating environment for best effect.***

4-3 Probe maintenance

User first time to use the meter

Intend to let the DO probe keep the best condition, when user receive the Oxygen Probe, it should fill the Probe's Electrolyte at first.

User already use the probe for a certain period :

Whenever user can not calibrate the meter properly or the meter's reading value is not stable, please check the oxygen probe to see if the electrolyte in the probe head container is run out or the diaphragm (probe head with diaphragm set) exist problem (dirty). If yes, please fill the electrolyte or change the " Probe head with diaphragm set " and make the new calibration.

The consideration of Diaphragm (probe head with diaphragm set

The oxygen probe component is the thin Teflon diaphragm housed in the tip of the probe. The diaphragm is permeable by the oxygen molecules but not by the considerably larger molecules contained in the electrolyte. Due to this characteristic, the oxygen may diffuse throughout the electrolyte solution contained in the probe, and its concentration may be quantified by the measurement circuit.

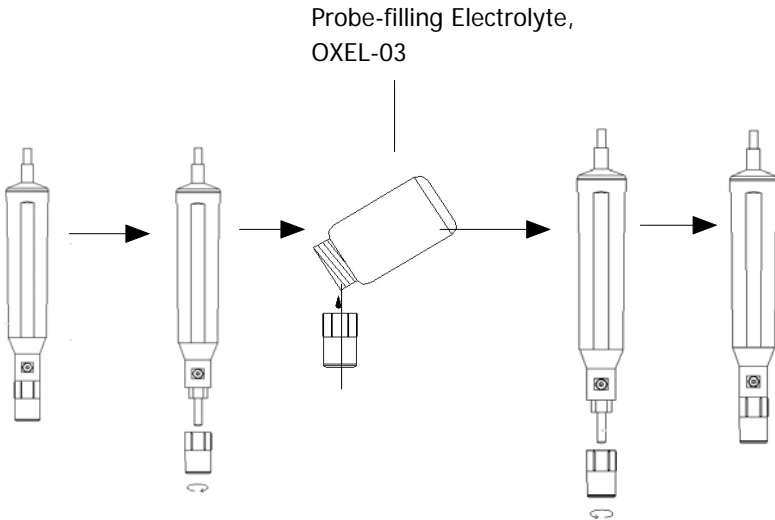

- 1) Unscrew the " Probe head " (5-3, Fig 3).
- 2) Pour out the old Electrolyte from the container of the " Probe head " .
- 3) Fill the new Electrolyte (OXEL-03) into the container of the " Probe head " .
- 4) Screw the " Probe head " (5-3, Fig 3) into the probe body.
- 5) **When not use the probe, should insert the " Probe head " into the " Probe protection cover " (4-5, Fig. 2)**

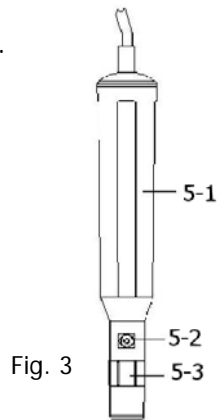

Fig. 3

- 5-1 Probe handle
- 5-2 Temp. sensing metal
- 5-3 Probe head

5. OTHER FUNCTION

5-1 Data Hold

During the measurement, press the " Hold Button " (3-3, Fig. 1) once will hold the measured value & the LCD will display a " HOLD " symbol.

Press the " Hold Button " once again will release the data hold function.

5-2 Data Record (Max., Min. reading)

1) The data record function records the maximum and minimum readings. Press the " REC Button " (3-4, Fig. 1) once to start the Data Record function and there will be a " REC. " symbol on the display.

2) With the " REC. " symbol on the display :

a) Press the " REC Button " (3-4, Fig. 1) once, the " REC. MAX. " symbol along with the maximum value will appear on the display.

If intend to delete the maximum value, just press the " Hold Button " (3-3, Fig. 1) once, then the display will show the " REC. " symbol only & execute the memory function continuously.

b) Press the " REC Button " (3-4, Fig. 1) again, the " REC. MIN. " symbol along with the minimum value will appear on the display.

If intend to delete the minimum value, just press the " Hold Button " (3-3, Fig. 1) once, then the display will show the " REC. " symbol only & execute the memory function continuously.

c) To exit the memory record function, just press the " REC " button for 2 seconds at least. The display will revert to the current reading.

5-3 LCD Backlight ON/OFF

After power ON, the " LCD Backlight " will light automatically. During the measurement, press the " Backlight Button " (3-2, Fig. 1) once will turn OFF the " LCD Backlight ".

Press the " Backlight Button " once again will turn ON the " LCD Backlight " again.

6. DATALOGGER

6-1 Preparation before execute datalogger function

a. Insert the SD card

Prepare a " SD memory card " (1 GB to 16 GB, optional), insert the SD card into the " SD card socket " (3-17, Fig. 1). The front panel of the SD card should face against the down case.

b. SD card Format

If SD card just the first time use into the meter, it recommend to make the " SD card Format " at first. , please refer chapter 8-1, page 22.

c. Time setting

If the meter is used at first time, it should to adjust the clock time exactly, please refer chapter 8-2, page 22.

d. Decimal format setting



The numerical data structure of SD card is default used the " ." as the decimal, for example "20.6" "1000.53" . But in certain countries (Europe ...) is used the " , " as the decimal point, for example " 20, 6 " "1000,53". Under such situation, it should change the Decimal character at first, details of setting the Decimal point, refer to Chapter 8-6, page 25.

6-2 Auto Datalogger (Set sampling time ≥ 1 second)

a. Start the datalogger

Press the " REC Button (3-4, Fig. 1) once , the LCD will show the text " REC " , then press the " Logger Button " (3-8, Fig. 1) , the bottom text " DATALOGGER " will flashing, at the same time the measuring data along the time information will be saved into the memory circuit.

Remark :

**How to set the sampling time, refer to Chapter 8-3 page 23.*

**How to set the beeper sound is enable, refer to Chapter 8-5, page 24.*

b. Pause the datalogger

During execute the Datalogger function , if press the " Logger Button " (3-8, Fig. 1) once will pause the Datalogger function (stop to save the measuring data into the memory circuit temporally). In the same time the text of " DATALOGGER " will be no flashing.

Remark :

If press the " Logger Button " (3-8, Fig. 1) once again will execute the Datalogger again, the bottom text of " DATALOGGER " will flashing .

c. Finish the Datalogger

During pause the Datalogger, press the " REC Button " (3-4, Fig. 1) continuously at least two seconds, the " REC " indication will be disappeared and finish the Datalogger.

6-3 Manual Datalogger (Set sampling time = 0 second)

a. Set sampling time is to 0 second

Press the " REC Button (3-4, Fig. 1) once , the LCD will show the text " REC ", then press the " Logger Button " (3-8, Fig. 1) once, the bottom text " DATALOGGER " will flashing once and Beeper will sound once, at the same time the measuring data along the time information will be saved into the memory circuit. The lower Display will show the Position (Location) no. and saved into the SD card too.

Remark :

During execute the Manual Datalogger, press the " ▲ Button " (3-5, Fig. 1) the lower no. (position no.) will flashing. It can use the " ▲ Button " (3-5, Fig. 1) or " ▼ Button " (3-6, Fig. 1) to set the measuring position (1 to 99, for example room 1 to room 99) to identify the measurement location , the lower Display will show P x (x = 1 to 99).

b. Finish the Datalogger

Press the " REC Button " (3-4, Fig. 1) continuously at least two seconds, the " REC " indication will be disappeared and finish the Datalogger.

6-4 To check the time information

During the normal measurement screen (not execute the Datalogger),

- 1) If press " Time Button " (3-7, Fig. 1) once , the lower LCD display will present the time information of Hour/Minute/Second (h.m.s) in the lower Display.
- 2) If press " Time Button " (3-7, Fig. 1) once again , the lower LCD display will present the time information of Year/Month/Date (yy.mm.dd) in the lower Display.
- 3) If press " Time Button " (3-7, Fig. 1) once again , the LCD will return to normal screen.

6-5 Check sampling time information

During the normal measurement screen (not execute the Datalogger), If press " Sampling Button " (3-8, Fig. 1) once , the lower LCD display will present the Sampling time information in second unit.

6-6 SD Card Data structure

- 1) When the first time, the SD card is used into the meter, the SD card will generate a route :

DOA01

- 2) If the first time to execute the Datalogger, under the route DOA01\, will generate a new file name DOA01001.XLS.
After exist the Datalogger, then execute again, the data will save to the DOA01001.XLS until Data column reach to 30,000 columns, then will generate a new file, for example DOA01002.XLS
- 3) Under the folder DOA01\, if the total files more than 99 files, will generate anew route, such as DOA02\

4) The file's route structure :

```

DOA01\
  DOA01001.XLS
  DOA01002.XLS
  .....
  DOA01099.XLS
DOA02\
  DOA02001.XLS
  DOA02002.XLS
  .....
  DOA02099.XLS
DOAXX\
  .....
  .....

```

Remark :
XX : Max. value is 10.

7. Saving data from the SD card to the computer (EXCEL software)

- 1) After execute the Data Logger function, take away the SD card out from the " SD card socket " (3-17, Fig. 1).
- 2) Plug in the SD card into the Computer's SD card slot (if your computer build in this installation) or insert the SD card into the " SD card adapter ". then connect the " SD card adapter " into the computer.
- 3) Power ON the computer and run the " EXCEL software ". Down load the saving data file (for example the file name : DOA01001.XLS, DOA01002.XLS) from the SD card to the computer. The saving data will present into the EXCEL software screen (for example as following EXCEL data screens) , then user can use those EXCEL data to make the further Data or Graphic analysis usefully.

EXCEL data screen (for example)

	A	B	C	D	E	F	G
1	Position	Date	Time	Ch1_Value	Ch1_Unit	Ch2_Value	Ch2_unit
2	1	2009/8/12	13:38:29	7.8	mg/L	27.9	Degree_C
3	2	2009/8/12	13:38:30	7.8	mg/L	27.9	Degree_C
4	3	2009/8/12	13:38:32	7.8	mg/L	27.9	Degree_C
5	4	2009/8/12	13:38:34	7.6	mg/L	27.9	Degree_C
6	5	2009/8/12	13:38:36	7.6	mg/L	27.9	Degree_C
7	6	2009/8/12	13:38:38	7.6	mg/L	27.9	Degree_C
8	7	2009/8/12	13:38:40	7.5	mg/L	27.9	Degree_C
9	8	2009/8/12	13:38:42	7.5	mg/L	27.9	Degree_C
10	9	2009/8/12	13:38:44	7.5	mg/L	27.9	Degree_C
11	10	2009/8/12	13:38:46	7.5	mg/L	27.9	Degree_C
12	11	2009/8/12	13:38:48	7.5	mg/L	27.9	Degree_C

EXCEL data screen/graphic screen (for example)

	A	B	C	D	E	F	G	H
1	Position	Date	Time	Ch1_Value	Ch1_Unit	Ch2_Value	Ch2_unit	
2	1	2009/8/12	13:38:29	7.8	mg/L	27.9	Degree_C	
3	2	2009/8/12	13:38:30	7.8	mg/L	27.9	Degree_C	
4	3	2009/8/12	13:38:32	7.8	mg/L	27.9	Degree_C	
5	4	2009/8/12	13:38:34	7.6	mg/L	27.9	Degree_C	
6	5	2009/8/12	13:38:36	7.6	mg/L	27.9	Degree_C	
7	6	2009/8/12	13:38:38	7.6	mg/L	27.9	Degree_C	
8	7	2009/8/12	13:38:40	7.5	mg/L	27.9	Degree_C	
9	8	2009/8/12	13:38:42	7.5	mg/L	27.9	Degree_C	
10	9	2009/8/12	13:38:44	7.5	mg/L	27.9	Degree_C	
11	10	2009/8/12	13:38:46	7.5	mg/L	27.9	Degree_C	
12	11	2009/8/12	13:38:48	7.5	mg/L	27.9	Degree_C	

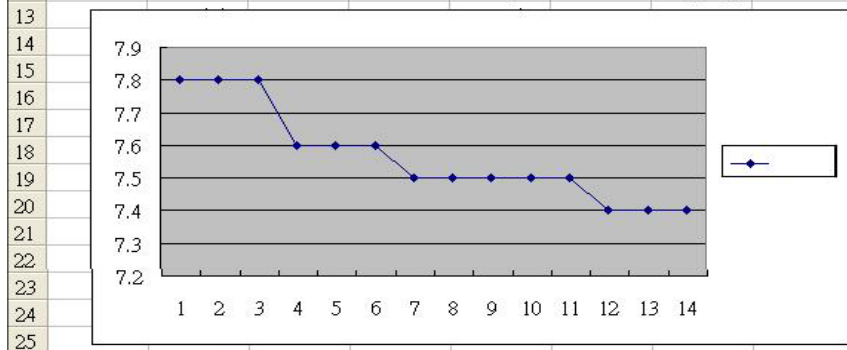

EXCEL graphic screen (for example 3, graphic)

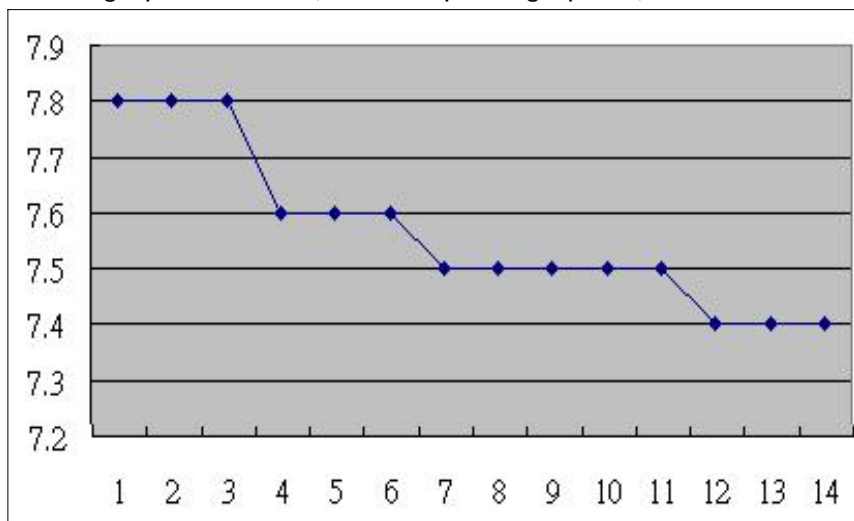

8. ADVANCED SETTING

Under do not execute the Datalogger function, press the " SET Button " (3-8, Fig. 1) continuously at least two seconds will enter the " Advanced Setting " mode. then press the " SET Button " (3-8, Fig. 1) once a while in sequence to select the eight main function, the display will show :

- Sd F**..... SD memory card Format
- dAtE**.....Set clock time (Year/Month/Date, Hour/Minute/Second)
- SP-t**..... Set sampling time (Hour/Minute/Second)
- PoFF**..... Auto power OFF management
- bEEP**.....Set beeper sound ON/OFF
- dEC**.....Set SD card Decimal character
- t-CF**..... Select the Temp. unit to °C or °F
- SALt**.....Set DO salt% compensation, DO only
- High-**.... Set DO height (meter) compensation, DO only
- Highf**.... Set DO height (feet) compensation, DO only
- ESC**..... Escape from the advanced setting

Remark :

During execute the " Advanced Setting " function, if press " ESC Button " (3-3, Fig. 1) will exit the " Advanced Setting " function, the LCD will return to normal screen.

8-1 SD memory card Format

When the lower display show " Sd F "

- 1) Use the " ▲ Button " (3-5, Fig. 1) or " ▼ Button " (3-6, Fig. 1) to select the upper value to " yES " or " no ".

yES - Intend to format the SD memory card
no - Not execute the SD memory card format

- 2) If select the upper to " yES ", press the " Enter Button " (3-4, Fig. 1) once again, the Display will show text " yES Enter " to confirm again, if make sure to do the SD memory card format, then press " Enter Button " once will format the SD memory clear all the existing data that already saving into the SD card.

8-2 Set clock time (Year/Month/Date, Hour/Minute/ Second)

When the upper display show " dAtE "

- 1) Use the " ▲ Button " (3-5, Fig. 1) or " ▼ Button " (3-6, Fig. 1) to adjust the value (Setting start from Year value). After the desired value is set, press the " Enter Button " (3-4, Fig. 1) once will going to next value adjustment (for example, first setting value is Year then next to adjust Month, Date, Hour, Minute, Second value).

Remark :

The adjusted value will be flashed.

- 2) After set all the time value (Year, Month, Date, Hour, Minute, Second), press the " SET Button " (3-8, Fig. 1) once will save the time value, then the screen will jump to " Sampling time " setting screen (Chapter 8-3).

Remark :

After the time value is setting, the internal clock will run precisely even Power off if the battery is under normal condition (No low battery power).

8-3 Set sampling time (Hour/Minute/Second)

When the upper display show " SP-t "

- 1) Use the " ▲ Button " (3-5, Fig. 1) or " ▼ Button " (3-6, Fig. 1) to adjust the value (Setting start from Hour value). After the desired value is set, press the " Enter Button " (3-4, Fig. 1) once will going to next value adjustment (for example, first setting value is Hour then next to adjust Minute, Second value).

Remark :

The adjusted value will be flashed.

- 2) After set all the sampling time value (Hour, Minute, Second), press the " SET Button " (3-8, Fig. 1) once will save the sampling value with default then the screen will jump to " Auto power OFF " setting screen (Chapter 8-4).

8-4 Auto power OFF management

When the lower display show " PoFF "

- 1) Use the " ▲ Button " (3-5, Fig. 1) or " ▼ Button " (3-6, Fig. 1) to select the upper value to " yES " or " no ".

yES - Auto Power Off management will enable.
no - Auto Power Off management will disable.

- 2) After select the upper text to " yES " or " no ", press the " Enter Button " (3-4, Fig. 1) will save the setting function with default.

8-5 Set beeper sound ON/OFF

When the lower display show " bEEP "

- 1) Use the " ▲ Button " (3-5, Fig. 1) or " ▼ Button " (3-6, Fig. 1) to select the upper value to " yES " or " no ".

yES - Meter's beep sound will be ON with default.
no - Meter's beep sound will be OFF with default.
is power ON.

- 2) After select the upper text to " yES " or " no ", press the " Enter Button " (3-4, Fig. 1) will save the setting function with default.

8-6 Decimal point of SD card setting

The numerical data structure of SD card is default used the " ." as the decimal, for example "20.6" "1000.53" . But in certain countries (Europe ...) is used the " ," as the decimal point, for example " 20,6 " "1000,53". Under such situation, it should change the Decimal character at first.

When the lower display show " dEC "

- 1) Use the " ▲ Button " (3-5, Fig. 1) or " ▼ Button " (3-6, Fig. 1) to select the upper text to " bASIC " or " Euro ".

bASIC - Use " ." as the Decimal point with default.

Euro - Use " ," as the Decimal point with default.

- 2) After select the upper text to " bASIC " or " Euro ", press the " Enter Button " (3-4, Fig. 1) will save the setting function with default.

8-7 Select the Temp. unit to °C or °F

When the lower display show " t-CF "

- 1) Use the " ▲ Button " (3-5, Fig. 1) or " ▼ Button " (3-6, Fig. 1) to select the upper Display text to " C " or " F ".

C - Temperature unit is °C

F - Temperature unit is °F

- 2) After Display unit is selected to " C " or " F ", press the " Enter Button " (3-4, Fig. 1) will save the setting function with default.

8-8 Set DO salt% compensation value

When the lower display show " SALT "

- 1) This function only for the DO (Dissolved oxygen) mode of adjusting the probe's salt% compensation value. The default value is 0% salt.
- 2) Use the " ▲ Button " (3-5, Fig. 1) or " ▼ Button " (3-6, Fig. 1) to select the upper value to the desired salt% compensation value, then press the " Enter " " Enter Button " (3-4, Fig. 1) will save the setting value temporarily.

8-9 Set DO height (meter) compensation value

When the lower display show " High- "

- 1) This function only for the DO (Dissolved oxygen) mode of adjusting the probe's height compensation value in meter unit. The default value is 0 meter.
- 2) Use the " ▲ Button " (3-5, Fig. 1) or " ▼ Button " (3-6, Fig. 1) to select the upper value to the desired height compensation value (meter), then press the " Enter Button " (3-4, Fig. 1) will save the setting value temporarily.

8-10 Set DO height (feet) compensation value

When the lower display show " Highf "

- 1) This function only for the DO (Dissolved oxygen) mode of adjusting the probe's height compensation value in feet unit. The default value is 0 FEET.
- 2) Use the " ▲ Button " (3-5, Fig. 1) or " ▼ Button " (3-6, Fig. 1) to select the upper value to the desired height compensation value (feet), then press the " Enter Button " (3-4, Fig. 1) will save the setting value temporarily.

8-11 ESC

When the display show " ESC "

When the Display show the text " ESC ", then press the " ESC Button " (3-3, Fig. 1) will finish the Advanced Setting procedures and return to the normal measuring screen.

Remark :

During execute the " Advanced Setting " function, if press " ESC Button " (3-3, Fig. 1) will exit the " Advanced Setting " function, the LCD will return to normal screen.

9. POWER SUPPLY from DC ADAPTER

The meter also can supply the power supply from the DC 9V Power Adapter (optional). Insert the plug of Power Adapter into " DC 9V Power Adapter Input Socket " (3-17, Fig. 1). The meter will permanent power ON when use the DC ADAPTER power supply (The power Button function is disable).

10. BATTERY REPLACEMENT

- 1) When the left corner of LCD display show " , it is necessary to replace the battery. However, in-spec. measurement may still be made for several hours after low battery indicator appears before the instrument become inaccurate.
- 2) Loose the screws of the " Battery Cover " (3-10, Fig. 1) and take away the " Battery Cover " from the instrument and remove the battery.
- 3) Replace with DC 1.5 V battery (UM3, AA, Alkaline/heavy duty) x 6 PCs, and reinstate the cover.
- 4) Make sure the battery cover is secured after changing batteries.

11. SYSTEM RESET

If the meter happen the troubles such as :

CPU system is hold (for example, the key button can not be operated...).

Then make the system RESET will fix the problem.
The system RESET procedures will be either following method :

During the power on, use a pin to press the " Reset Button " (3-15, Fig. 1) once a while will reset the circuit system.

12. RS232 PC SERIAL INTERFACE

The instrument has RS232 PC serial interface via a 3.5 mm terminal (3-16, Fig. 1).

The data output is a 16 digit stream which can be utilized for user's specific application.

A RS232 lead with the following connection will be required to link the instrument with the PC serial port.

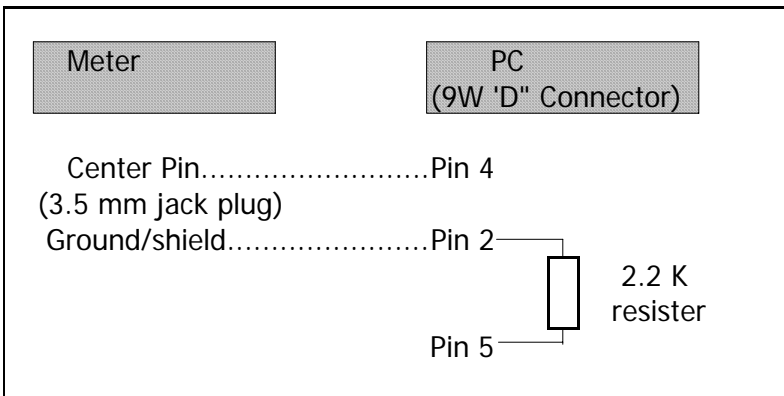

The 16 digits data stream will be displayed in the following format :

D15 D14 D13 D12 D11 D10 D9 D8 D7 D6 D5 D4 D3 D2 D1 D0

Each digit indicates the following status :

D15	Start Word
D14	4
D13	When send the upper display data = 1 When send the lower display data = 2

D12, D11	Annunciator for Display		
	mg/L = 07	% O2 = 06	
D10	Polarity 0 = Positive 1 = Negative		
D8 to D1	Display reading, D1 = LSD, D8 = MSD For example : If the display reading is 1234, then D8 to D1 is : 00001234		
D0	End Word		

RS232 FORMAT : 9600, N, 8, 1

Baud rate	9600
Parity	No parity
Data bit no.	8 Data bits
Stop bit	1 Stop bit

13. OPTIONAL ACCESSORIES

RS232 cable UPCB-02	* Computer interface cable. * Used to connect the meter to the computer (COM port).
USB cable USB-01	* Computer interface cable. * Used to connect the meter to the computer (USB port).

Data Acquisition software SW-U801-WIN	* The SW-U801-WIN is a multi displays (1/2/4/6/8 displays) powerful application software, provides the functions of data logging system, text display, angular display, chart display, data recorder high/low limit, data query, text report, chart report.. .xxx.mdb data file can be retrieved for EXCEL, ACCESS., wide intelligent applications.
Power adapter	AC 110V to DC 9V. USA plug.
Power adapter	AC 220V/230V to DC 9V. Germany plug.
Dissolved Oxygen optional accessories	* Oxygen probe Model : OXPB-11
	* Spare Probe head with Diaphragm set Model : OXHD-04
	* Probe-filling Electrolyte Model : OXEL-03

14. PATENT

The meter (SD card structure) already get patent or patent pending in following countries :

Germany	Nr. 20 2008 016 337.4
JAPAN	3151214
TAIWAN	M 358970 M 359043
CHINA	ZL 2008 2 0189918.5 ZL 2008 2 0189917.0
USA	Patent pending