

SD card real time datalogger, RS232/USB

VACUUM METER

Model : VC-9210SD



Your purchase of this VACUUM METER with S D C A R D D A T A L O G G E R marks a step forward for you into the field of precision measurement. Although this METER is a complex and delicate instrument, its durable structure will allow many years of use if proper operating techniques are developed. Please read the following instructions carefully and always keep this manual within easy reach.

OPERATION MANUAL

TABLE OF CONTENTS

1. FEATURES.....	1
2. SPECIFICATIONS.....	2
2-1 General Specifications.....	2
2-2 Electrical Specifications.....	4
3. FRONT PANEL DESCRIPTION.....	5
4. MEASURING PROCEDURE.....	7
5. OTHER FUNCTION.....	8
5-1 Data Hold.....	8
5-2 Record (Max./ Min. reading).....	8
5-3 LCD Backlight ON/OFF.....	9
6. DATALOGGER.....	9
6-1 Preparation before execute datalogger function.....	9
6-2 Auto Datalogger (Set sampling time \geq 1 second).....	10
6-3 Manual Datalogger (Set sampling time = 0 second).....	11
6-4 Check time information.....	12
6-5 Check sampling time information.....	12
6-6 SD Card Data structure.....	12
7. Saving data from the SD card to the computer.....	13
8. ADVANCED SETTING.....	16
9. POWER SUPPLY from DC ADAPTER.....	21
10. BATTERY REPLACEMENT.....	21
11. SYSTEM RESET.....	22
12. RS232 PC SERIAL INTERFACE.....	22
13. OTHER OPTIONAL ACCESSORIES.....	24
14. PATENT.....	25

1. FEATURES

- * Absolute vacuum & absolute pressure measurement.
- * Wide measure range from 1 to 1500 mbar.
- * Overload protection up to 2000 mbar max.
- * Separate probe, easy operation.
- * Application : Automobile, Industrial, laboratory, heating, ventilation, medical hospital.....
- * Heavy duty sensor used for air, oil gas, liquid.
- * 7 kind display units (torr, mm Hg, mbar, KPa, hPa, inch Hg, psi) select by push button on the front panel.
- * Microprocessor circuit assures maximum possible accuracy, provides special functions and features,
- * Real time SD memory card Datalogger, built-in Clock and Calendar, sampling time can set from 1 sec to 8 hour 59 min. 59 sec.
- * Manual datalogger is available, during execute the manual datalogger function, it can set the different location no. (position 1 to position 99).
- * Innovation and easy operation, computer is not need to setup extra software, after execute datalogger, just take away the SD card from the meter and plug in the SD card into the computer, it can down load the all the measured value with the time information (year/month/date/ hour/minute/second) to the Excel directly, the user can make the further data or graphic analysis by themselves.
- * SD card capacity : 1 GB to 16 GB.
- * LCD with green light backlight, easy reading.
- * It can default auto power off or manual power off.
- * Data hold, record max. and min. reading.
- * Microcomputer circuit, high accuracy.
- * Power by UM3/AA (1.5 V) x 6 batteries or DC 9V adapter.
- * RS232/USB PC computer interface.

2. SPECIFICATIONS

2-1 General Specifications

Circuit	Custom one-chip of microprocessor LSI circuit.	
Display	LCD size : 52 mm x 38 mm LCD with green backlight (ON/OFF).	
Display units	7 kind display units : torr, mm Hg, mbar, KPa, hPa, inch Hg, psi.	
Zero adjust	Push button on the front panel.	
Span adjust	Push button gain adjustment, usage for calibration precisely if necessary.	
Datalogger Sampling Time Setting range	Auto	1 sec to 8 hour 59 min. 59 sec. <i>@ Sampling time can set to 1 second, but memory data may loss.</i>
	Manual	Push the data logger button once will save data one time. <i>@ Set the sampling time to 0 second.</i> <i>@ Manual mode, can also select the 1 to 99 position (Location) no.</i>
Data error no.	0.1% of total saved data max.	
Memory Card	SD memory card. 1 GB to 16 GB.	
Advanced setting	<ul style="list-style-type: none"> * SD memory card Format * Set clock time (Year/Month/Date, Hour/Minute/Second) * Set sampling time * Auto power OFF management * Set beep Sound ON/OFF * Decimal point of SD card setting 	
Data Hold	Freeze the display reading.	
Memory Recall	Maximum & Minimum value.	
Sampling Time of Display	Approx. 1 second.	

Data Output	RS 232/USB PC computer interface. * <i>Connect the optional RS232 cable UPCB-02 will get the RS232 plug.</i> * <i>Connect the optional USB cable USB-01 will get the USB plug.</i>
Operating Temperature	0 to 50 °C . (32 to 122 °F).
Operating Humidity	Less than 80% R.H.
Power Supply	* .Alkaline or heavy duty DC 1.5 V battery (UM3, AA) x 6 PCs, or equivalent. * .DC 9V adapter input. (AC/DC power adapter is optional).
Power Current	Normal operation (w/o SD card save data and LCD Backlight is OFF) : <i>Approx. DC 5 mA.</i> When SD card save the data and LCD Backlight is OFF) : <i>Approx. DC 25 mA.</i> * . <i>If LCD backlight on, the power consumption will increase approx. 12 mA.</i>
Weight	350 g/0.77 LB.
Dimension	177 x 68 x 45 mm (7.0 x 2.7x 1.9 inch) * <i>Meter only</i>
Accessories Included	Instruction manual.....1 PC Vacuum sensor probe.....1 PC Hard carrying case, CA-06..... 1 PC
Optional Accessories	Soft carrying case, CA-05A. SD memory card (1 GB) SD memory card (2 GB) AC to DC 9V adapter. USB cable, USB-01. RS232 cable, UPCB-02. Data Acquisition software, SW-U801-WIN.

2-2 Electrical Specifications (23± 5 °C)

Unit	Max. range	Resolution	Accuracy
mbar	1500 mbar	1 mbar	± 1 % F. S. (23± 5 °C) <i>Note :</i> <i>Included linearity,</i> <i>hysteresis and</i> <i>repeatability</i> F.S.: Full Scale
KPa	150.0 KPa	0.1 KPa	
hPa	1500 hPa	1 hPa	
torr	1125 torr	1 torr	
mm Hg	1125 mm Hg	1 mm Hg	
inch Hg	44.30 inch Hg	0.02 inch Hg	
psi	21.75 psi	0.01 psi	

Remark :

If intend to show the " micron " unit, just select to the " mmHg " unit, then x 1000.

3. FRONT PANEL DESCRIPTION

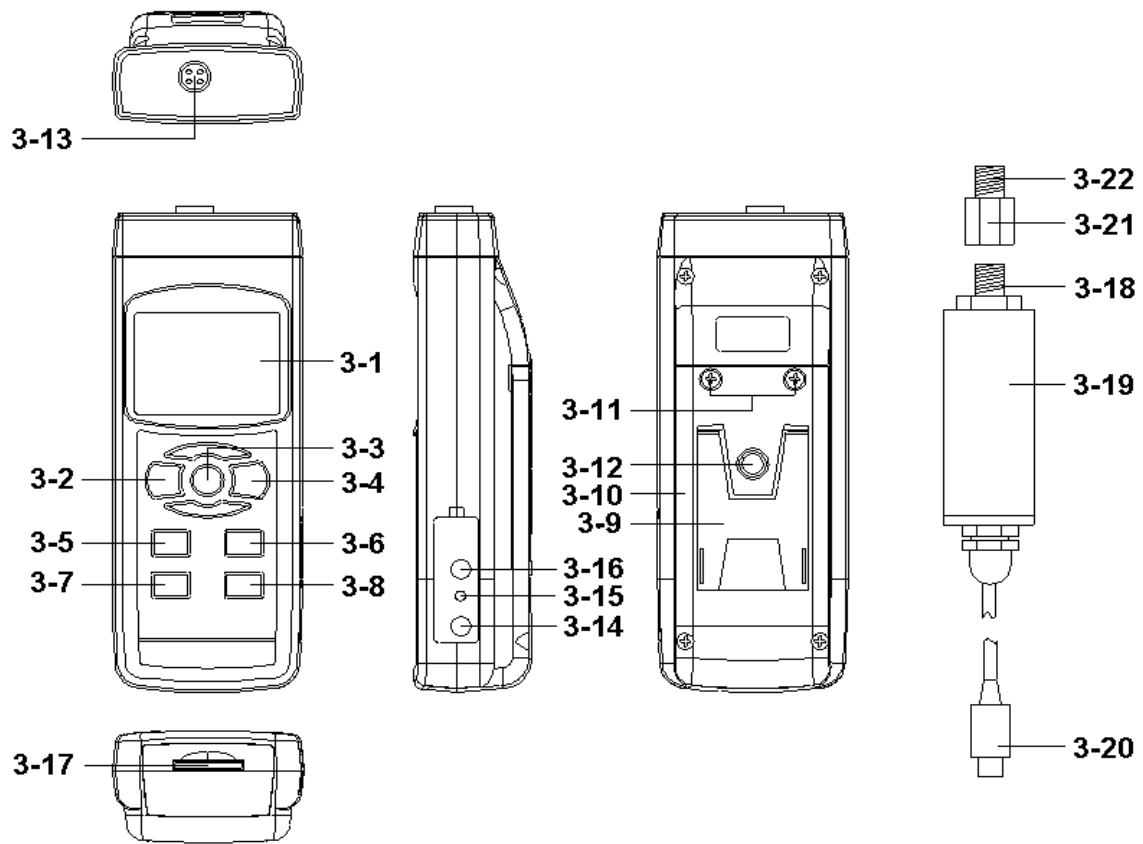

Fig. 1

- 3-1 Display
- 3-2 Power Button (Backlight Button)
- 3-3 Hold Button (ESC Button)
- 3-4 REC Button (Enter Button)
- 3-5 Unit Button (▲ Button)
- 3-6 Sensor type Button (▼ Button)
- 3-7 Zero Button (Time Button)
- 3-8 Logger Button (SET Button, Sampling check)
- 3-9 Stand
- 3-10 Battery Compartment/Cover
- 3-11 Battery Cover Screw
- 3-12 Tripod Fix Nut
- 3-13 Probe Socket
- 3-14 DC 9V Power Adapter Input Socket
- 3-15 Reset Button
- 3-16 RS-232 Output Terminal
- 3-17 SD card socket
- 3-18 Port Connector (1/4" NPT)
- 3-19 Vacuum Sensor Main body
- 3-20 Plug of Vacuum Sensor
- 3-21 Adapter connector that
convert 1/4" NPT to 1/4" PS
- 3-22 Port Connector (1/4" PS)

4. MEASURING PROCEDURE

- 1) Plug in the " Plug of Vacuum Sensor " (3-20, Fig. 1) to meter's " Probe Input Socket " (3-13, Fig. 1)
- 2) Power on the meter by pushing the " Power Button " (3-2, Fig. 1) once.
- 4) Press the " Unit Button " (3-5, Fig. 1) once in sequence to select the measuring 7 kind units as : mBar, mmHg, KPA, hPA, inch Hg, Psi, torr.

<i>Unit</i>	<i>Display indicator</i>
Psi	PSI
inch Hg	In Hg
hPA	hPA
KPA	_PA
mBar	- bAr
mm Hg	--Hg
torr	torr

Remark :

**** After select the desired unit, power off the meter then power on again, the meter circuit memory will save the selected unit with default.***

**** If intend to show the " micron " unit, just select to the " mmHg " unit, then x 1000.***

- 5) Zero adjustment :
Power on the meter, disconnect the " Vacuum sensor " from the meter, if the Display is not show zero value, push the " Zero Button " (3-7, Fig. 1), > 10 seconds continuously, the Display value will change to zero value.

- 6) Connect the " Port Connector " (3-18, 3-22, Fig. 1) to the equipment that intend to be measured the vacuum value.

5. OTHER FUNCTION

5-1 Data Hold

During the measurement, press the " Hold Button " (3-3, Fig. 1) once will hold the measured value & the LCD will display a " HOLD " symbol.

Press the " Hold Button " once again will release the data hold function.

5-2 Data Record (Max., Min. reading)

1) The data record function records the maximum and minimum readings. Press the " REC Button " (3-4, Fig. 1) once to start the Data Record function and there will be a " REC " symbol on the display.

2) With the " REC " symbol on the display :

a) Press the " REC Button " (3-4, Fig. 1) once, the " REC MAX " symbol along with the maximum value will appear on the display.

If intend to delete the maximum value, just press the " Hold Button " (3-3, Fig. 1) once, then the display will show the " REC " symbol only & execute the memory function continuously.

b) Press the " REC Button " (3-4, Fig. 1) again, the " REC MIN " symbol along with the minimum value will appear on the display.

If intend to delete the minimum value, just press the " Hold Button " (3-3, Fig. 1) once, then the display will show the " REC " symbol only & execute the memory function continuously.

- c) To exit the memory record function, just press the " REC Button " for 2 seconds at least. The display will revert to the current reading.

5-3 LCD Backlight ON/OFF

After power ON, the " LCD Backlight " will light automatically. During the measurement, press the " Backlight Button " (3-2, Fig. 1) once will turn OFF the " LCD Backlight ".

Press the " Backlight Button " once again will turn ON the " LCD Backlight " again.

6. DATALOGGER

6-1 Preparation before execute datalogger function

a. Insert the SD card

** It recommend use memory card \leq 4 GB.*

Prepare a " SD memory card " (1 GB to 16 GB, optional), insert the SD card into the " SD card socket " (3-17, Fig. 1). The front panel of the SD card should face against the down case.

b. SD card Format

If SD card just the first time use into the meter, it recommend to make the " SD card Format " at first. , please refer chapter 8-1, page 17.

** It recommend strongly, do not use memory cards that have been formatted by other meter or by a computer. Reformat the memory card with your meter.*

c. Time setting

If the meter is used at first time, it should to adjust the clock time exactly, please refer chapter 8-2, page 17.

d. Decimal format setting



The numerical data structure of SD card is default used the "." as the decimal, for example "20.6" "1000.53". But in certain countries (Europe ...) is used the "," as the decimal point, for example " 20, 6 " "1000,53". Under such situation, it should change the Decimal character at first, details of setting the Decimal point, refer to Chapter 8-6, page 20.

6-2 Auto Datalogger (Set sampling time ≥ 1 second)

a. Start the datalogger

Press the " REC Button (3-4, Fig. 1) once , the LCD will show the text " REC ", then press the " Logger Button " (3-8, Fig. 1), the bottom text " DATALOGGER " will flashing, at the same time the measuring data along the time information will be saved into the memory circuit.

Remark :

**How to set the sampling time, refer to Chapter 8-3 page 18.*

**How to set the beeper sound is enable, refer to Chapter 8-5, page 19.*

b. Pause the datalogger

During execute the Datalogger function , if press the " Logger Button " (3-8, Fig. 1) once will pause the Datalogger function (stop to save the measuring data into the memory circuit temporally). In the same time the text of " DATALOGGER " will be no flashing.

Remark :

If press the " Logger Button " (3-8, Fig. 1) once again will execute the Datalogger again, the bottom text of " DATALOGGER " will flashing .

c. Finish the Datalogger

During pause the Datalogger, press the " REC Button " (3-4, Fig. 1) continuously at least two seconds, the " REC " indication will be disappeared and finish the Datalogger.

6-3 Manual Datalogger (Set sampling time = 0 second)

a. Set sampling time is to 0 second

Press the " REC Button (3-4, Fig. 1) once , the LCD will show the text " REC " , then press the " Logger Button " (3-8, Fig. 1) once, the bottom text " DATALOGGER " will flashing once and Beeper will sound once, at the same time the measuring data along the time information will be saved into the memory circuit. The lower Display will show the Position (Location) no. and saved into the SD card too.

Remark :

During execute the Manual Datalogger, press the " ▲ Button " (3-5, Fig, 1) the lower no. (position no.) will flashing. It can use the " ▲ Button " (3-5, Fig. 1) or " ▼ Button " (3-6, Fig. 1) to set the measuring Location no. (1 to 99, for example room 1 to room 99) to identify the measurement location , the lower Display will show P x (x = 1 to 99).

b. Finish the Datalogger

Press the " REC Button " (3-4, Fig. 1) continuously at least two seconds, the " REC " indication will be disappeared and finish the Datalogger.

6-4 To check the time information

During the normal measurement screen (not execute the Datalogger),

- 1) If press " Time Button " (3-7, Fig. 1) once , the lower LCD display will present the time information of Hour/Minute/Second (h.m.s) in the lower Display.
- 2) If press " Time Button " (3-7, Fig. 1) once again , the lower LCD display will present the time information of Year/Month/Date (yy.mm.dd) in the lower Display.
- 3) If press " Time Button " (3-7, Fig. 1) once again , the LCD will return to normal screen.

6-5 Check sampling time information

During the normal measurement screen (not execute the Datalogger), If press " Sampling Button " (3-8, Fig. 1) once , the lower LCD display will present the Sampling time information in second unit.

6-6 SD Card Data structure

- 1) When the first time, the SD card is used into the meter, the SD card will generate a route :

VCA01

- 2) If the first time to execute the Datalogger, under the route VCA01\, will generate a new file name VCA01001.XLS.
After exist the Datalogger, then execute again, the data will save to the VCA01001.XLS until Data column reach to 30,000 columns, then will generate a new file, for example VCA01002.XLS
- 3) Under the folder VCA01\, if the total files more than 99 files, will generate anew route, such as VCA02\
- 4) The file's route structure :
 - VCA01\
 - VCA01001.XLS
 - VCA01002.XLS
 -
 - VCA01099.XLS
 - VCA02\
 - VCA02001.XLS
 - VCA02002.XLS
 -
 - VCA02099.XLS
 - VCAXX\
 -
 -

Remark :
XX : Max. value is 10.

7. Saving data from the SD card to the computer (EXCEL software)

- 1) After execute the Data Logger function, take away the SD card out from the " SD card socket " (3-17, Fig. 1).

- 2) Plug in the SD card into the Computer's SD card slot (if your computer build in this installation) or insert the SD card into the " SD card adapter ". then connect the " SD card adapter " into the computer.
- 3) Power ON the computer and run the " EXCEL software ". Down load the saving data file (for example the file name : VCA01001.XLS, VCA01002.XLS) from the SD card to the computer. The saving data will present into the EXCEL software screen (for example as following EXCEL data screens) , then user can use those EXCEL data to make the further Data or Graphic analysis usefully.

EXCEL data screen (for example)

	A	B	C	D	E
1	Position	Date	Time	Ch1_Value	Ch1_Unit
2	1	2010/9/23	17:06:11	754	torr
3	2	2010/9/23	17:06:13	755	torr
4	3	2010/9/23	17:06:15	753	torr
5	4	2010/9/23	17:06:17	756	torr
6	5	2010/9/23	17:06:19	752	torr
7	6	2010/9/23	17:06:21	754	torr
8	7	2010/9/23	17:06:23	751	torr
9	8	2010/9/23	17:06:25	756	torr
10	9	2010/9/23	17:06:27	760	torr
11	10	2010/9/23	17:06:29	761	torr
12	11	2010/9/23	17:06:31	760	torr
13	12	2010/9/23	17:06:33	756	torr
14	13	2010/9/23	17:06:35	756	torr
15					

EXCEL graphic screen (for example, graphic)

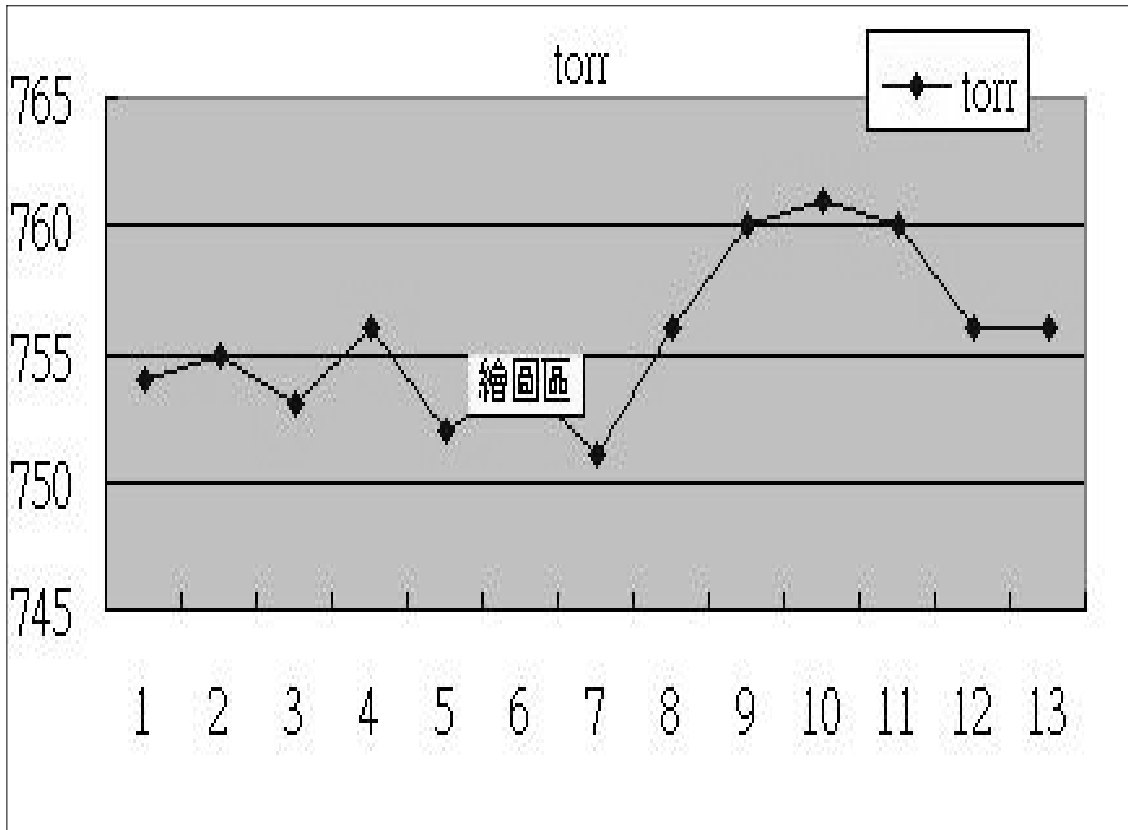

8. ADVANCED SETTING

Under do not execute the Datalogger function, press the " SET Button " (3-8, Fig. 1) continuously at least two seconds will enter the " Advanced Setting " mode. then press the " SET Button " (3-8, Fig. 1) once a while in sequence to select the seven main function, the display will show :

- Sd F**..... SD memory card Format
- dAtE**.....Set clock time (Year/Month/Date, Hour/Minute/Second)
- SP-t**.....Set sampling time (Hour/Minute/Second)
- PoFF**.....Auto power OFF management
- bEEP**.....Set beeper sound ON/OFF
- dEC**.....Set SD card Decimal character
- ESC**..... Escape from the advanced setting

Remark :

During execute the " Advanced Setting " function, if press " ESC Button " (3-3, Fig. 1) will exit the " Advanced Setting " function, the LCD will return to normal screen.

8-1 SD memory card Format

When the lower display show " Sd F "

- 1) Use the " ▲ Button " (3-5, Fig. 1) or " ▼ Button " (3-6, Fig. 1) to select the upper value to " yES " or " no ".

yES - Intend to format the SD memory card
no - Not execute the SD memory card format

- 2) If select the upper to " yES ", press the " Enter Button " (3-4, Fig. 1) once again, the Display will show text " yES Enter " to confirm again, if make sure to do the SD memory card format, then press " Enter Button " once will format the SD memory clear all the existing data that already saving into the SD card.

8-2 Set clock time (Year/Month/Date, Hour/Minute/ Second)

When the upper display show " dAtE "

- 1) Use the " ▲ Button " (3-5, Fig. 1) or " ▼ Button " (3-6, Fig. 1) to adjust the value (Setting start from Year value). After the desired value is set, press the " Enter Button " (3-4, Fig. 1) once will going to next value adjustment (for example, first setting value is Year then next to adjust Month, Date, Hour, Minute, Second value).

Remark :
The adjusted value will be flashed.

- 2) After set all the time value (Year, Month, Date, Hour, Minute, Second), press the " SET Button " (3-8, Fig. 1) once will save the time value, then the screen will jump to " Sampling time " setting screen (Chapter 8-3).

Remark :

After the time value is setting, the internal clock will run precisely even Power off if the battery is under normal condition (No low battery power).

8-3 Set sampling time (Hour/Minute/Second)

When the upper display show " SP-t "

- 1) Use the " ▲ Button " (3-5, Fig. 1) or " ▼ Button " (3-6, Fig. 1) to adjust the value (Setting start from Hour value). After the desired value is set, press the " Enter Button " (3-4, Fig. 1) once will going to next value adjustment (for example, first setting value is Hour then next to adjust Minute, Second value).

Remark :

The adjusted value will be flashed.

- 2) After set all the sampling time value (Hour, Minute, Second), press the " SET Button " (3-8, Fig. 1) once will save the sampling value with default then the screen will jump to " Auto power OFF " setting screen (Chapter 8-4).

8-4 Auto power OFF management

When the lower display show " PoFF "

- 1) Use the " ▲ Button " (3-5, Fig. 1) or " ▼ Button " (3-6, Fig. 1) to select the upper value to " yES " or " no ".

yES - Auto Power Off management will enable.
no - Auto Power Off management will disable.

- 2) After select the upper text to " yES " or " no ", press the " Enter Button " (3-4, Fig. 1) will save the setting function with default.

8-5 Set beeper sound ON/OFF

When the lower display show " bEEP "

- 1) Use the " ▲ Button " (3-5, Fig. 1) or " ▼ Button " (3-6, Fig. 1) to select the upper value to " yES " or " no ".

yES - Meter's beep sound will be ON with default.
no - Meter's beep sound will be OFF with default.

Remark :

Beep sound ON/OFF setting is available when execute Datalogger function. When press the buttons, will always generate one sound beeper.

- 2) After select the upper text to " yES " or " no ", press the " Enter Button " (3-4, Fig. 1) will save the setting function with default.

8-6 Decimal point of SD card setting

The numerical data structure of SD card is default used the " ." as the decimal, for example "20.6" "1000.53" . But in certain countries (Europe ...) is used the " ," as the decimal point, for example " 20,6 " "1000,53". Under such situation, it should change the Decimal character at first.

When the lower display show " dEC "

1) Use the " ▲ Button " (3-5, Fig. 1) or " ▼ Button " (3-6, Fig. 1) to select the upper text to " bASIC " or " Euro " .

bASIC - Use " ." as the Decimal point with default.
Euro - Use " ," as the Decimal point with default.

2) After select the upper text to " bASIC " or " Euro " , press the " Enter Button " (3-4, Fig. 1) will save the setting function with default.

8-7 ESC

When the display show " ESC "

When the Display show the text " ESC " , then press the " SET Button " (3-8, Fig. 1) or " ESC Button " (3-3, Fig. 1) will finish the Advanced Setting procedures.

Remark :

During execute the " Advanced Setting " function, if press " ESC Button " (3-3, Fig. 1) will exit the " Advanced Setting " function, the LCD will return to normal screen.

9. POWER SUPPLY from DC ADAPTER

The meter also can supply the power supply from the DC 9V Power Adapter (optional). Insert the plug of Power Adapter into " DC 9V Power Adapter Input Socket " (3-14, Fig. 1). The meter will permanent power ON when use the DC ADAPTER power supply (The power Button function is disable).

10. BATTERY REPLACEMENT

- 1) When the left corner of LCD display show " , it is necessary to replace the battery. However, in-spec. measurement may still be made for several hours after low battery indicator appears before the instrument become inaccurate.
- 2) Loose the screws of the " Battery Cover " (3-11, Fig. 1) and take away the " Battery Cover " from the instrument and remove the battery.
- 3) Replace with DC 1.5 V battery (UM3, AA, Alkaline/heavy duty) x 6 PCs, and reinstate the cover.
- 4) Make sure the battery cover is secured after changing batteries.

11. SYSTEM RESET

If the meter happen the troubles such as :

CPU system is hold (for example, the key button can not be operated...).

Then make the system RESET will fix the problem.
The system RESET procedures will be either following method :

During the power on, use a pin to press the " Reset Button " (3-15, Fig. 1) once a while will reset the circuit system.

12. RS232 PC SERIAL INTERFACE

The instrument has RS232 PC serial interface via a 3.5 mm terminal (3-16, Fig. 1).

The data output is a 16 digit stream which can be utilized for user's specific application.

A RS232 lead with the following connection will be required to link the instrument with the PC serial port.

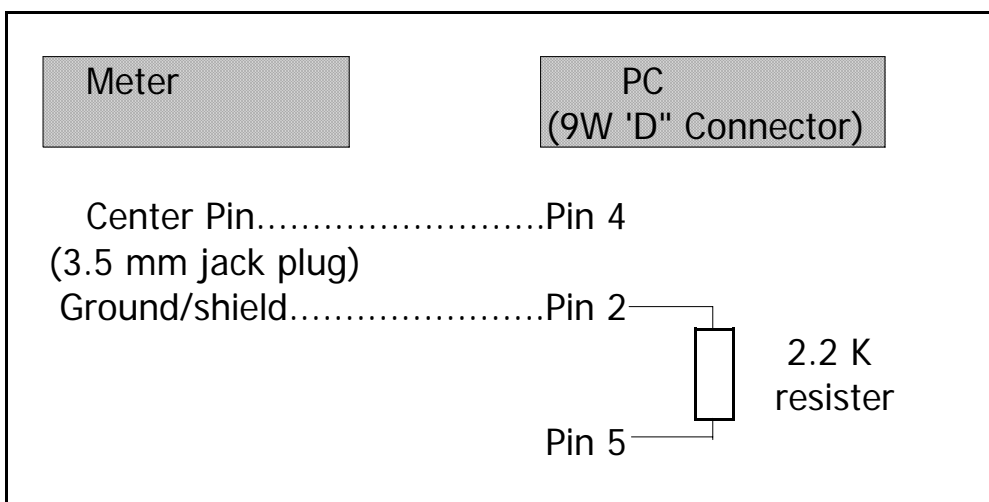

The 16 digits data stream will be displayed in the following format :

D15 D14 D13 D12 D11 D10 D9 D8 D7 D6 D5 D4 D3 D2 D1 D0

Each digit indicates the following status :

D15	Start Word		
D14	4		
D13	When send the upper display data = 1 When send the lower display data = 2		
D12, D11	Annunciator for Display		
	mBar = 86	mm Hg = 78	torr = 90
	Psi = 23	inch Hg = 80	
	hPA = 91	kPA = 88	
D10	Polarity 0 = Positive 1 = Negative		
D9	Decimal Point(DP), position from right to the left 0 = No DP, 1= 1 DP, 2 = 2 DP, 3 = 3 DP		
D8 to D1	Display reading, D1 = LSD, D8 = MSD For example : If the display reading is 1234, then D8 to D1 is : 00001234		
D0	End Word		

RS232 FORMAT : 9600, N, 8, 1

Baud rate	9600
Parity	No parity
Data bit no.	8 Data bits
Stop bit	1 Stop bit

13. OTHER OPTIONAL ACCESSORIES

Memory card	SD memory card (2 GB)
RS232 cable UPCB-02	* Computer interface cable. * Used to connect the meter to the computer (COM port).
USB cable USB-01	* Computer interface cable. * Used to connect the meter to the computer (USB port).
Data Acquisition software SW-U801-WIN	The The SW-U801-WIN is a multi displays (1/2/4/6/8 displays) powerful application software, provides the functions of data logging system, text display, angular display, chart display, data recorder high/low limit, data query, text data recorder high/low limit, data report, chart report.. .xxx.mdb data file can be retrieved for EXCEL, ACCESS., wide intelligent applications.
Power adapter	AC 110V to DC 9V. USA plug. AC 220V/230V to DC 9V. Germany plug.

14. PATENT

The meter (SD card structure) already get patent or patent pending in following countries :

Germany	Nr. 20 2008 016 337.4
JAPAN	3151214
TAIWAN	M 358970
	M 359043
CHINA	ZL 2008 2 0189918.5
	ZL 2008 2 0189917.0
USA	Patent pending