

TABLE OF CONTENTS

1. FEATURES.....	1
2. SPECIFICATIONS.....	2
3. FRONT PANEL DESCRIPTION.....	7
4. MEASURING PROCEDURE.....	8
4-1 Function selection	8
4-2 Air velocity/Temp. measurement.....	9
4-3 Air flow measurement.....	11
4-4 Type K/J thermometer	12
4-5 Data Hold.....	12
4-6 Data Record (Max., Min. reading).....	12
4-7 LCD Backlight ON/OFF.....	13
5. DATALOGGER.....	14
5-1 Preparation before execute datalogger function.....	14
5-2 Auto Datalogger (Set sampling time ≥ 1 second).....	14
5-3 Manual Datalogger (Set sampling time = 0 second).....	16
5-4 Check time information.....	16
5-5 SD Card Data structure.....	17
6. Saving data from the SD card to the computer.....	18
7. ADVANCED SETTING.....	20
7-1 Set clock time (Year/Month/Date, Hour/Minute/Second).....	20
7-2 Set sampling time	21
7-3 Auto power OFF management	21
7-4 Set beep Sound ON/OFF.....	22
7-5 Decimal point of SD card setting.....	22
7-6 SD memory card format.....	23
7-7 Select the temperature unit to $^{\circ}\text{C}$ or $^{\circ}\text{F}$	23
7-8 Select the thermometer type to Type K or Type J.....	24
7-9 Set air flow type (CFM/USA, CMM/EURO).....	24
7-10 Set air flow area dimension.....	25
8. POWER SUPPLY from DC ADAPTER.....	26
9. BATTERY REPLACEMENT.....	26
10. SYSTEM RESET.....	27
11. RS232 PC serial interface.....	27
12. Optional Type K Temp. probe.....	29
13. PATENT.....	29

1. FEATURES

- * One meter can accept two probes :
Hot wire anemometer probe
- * Combination of hot wire and standard thermistor, deliver rapid and precise measurements even at low air velocity value.
- * Slim hot wire probe, ideal for grilles & diffusers.
- * Air velocity : m/s, Ft/min, Km/h, Knot, Mile/h,
- * Air flow (CFM, CMM) measurement.
- * Air temperature (°C, °F)
- * Air Temp. used thermistor sensor, fast response time.
- * Fast humidity measuring response time.
- * Type K, Type J thermocouple thermometer.
- * Real time SD memory card Datalogger, it Built-in Clock and Calendar, real time data recorder , sampling time set from 1 second to 3600 seconds.
- * Manual datalogger is available (set the sampling time to 0), during execute the manual datalogger function, it can set the different position (location) No. (position 1 to position 99).
- * Innovation and easy operation, computer is not need to setup extra software, after execute datalogger, just take away the SD card from the meter and plug in the SD card into the computer, it can down load the all the measured value with the time information (year/month/date/ hour/minute/second) to the Excel directly, then user can make the further data or graphic analysis by themselves.
- * SD card capacity : 1 GB to 16 GB.
- * LCD with green light backlight, easy reading.
- * Can default auto power off or manual power off.
- * Data hold, record max. and min. reading.
- * Microcomputer circuit, high accuracy.

- * Power by UM3/AA (1.5 V) x 6 batteries or DC 9V adapter.
- * RS232/USB PC COMPUTER interface.
- * Separate probe, easy for operation.
- * Applications : Environmental testing, HVAC, Air conveyors, Flow hoods, Clean rooms, Air velocity, Air balancing, Fans/motors/blowers, Furnace velocity, Refrigerated case, Paint spray booths . measurements

2. SPECIFICATIONS

2-1 General Specifications

Circuit	Custom one-chip of microprocessor LSI circuit.
Display	LCD size : 52 mm x 38 mm LCD with green backlight (ON/OFF).
Measurement Unit	<i>Air velocity:</i> m/s (meters per second) Km/h (kilometers per hour) Ft/min (FPM, feet per minute) Knots (nautical miles per hour) Mile/h (mph, miles per hour) <i>Air flow :</i> CFM, CMM * CFM : cube feet per minute * CFM : cube meters per minute °C, °F <hr/> <i>Type K/ Type J thermometer : °C , °F</i> <hr/> <i>Air temperature: °C , °F</i>

Sensor Structure	<i>Air velocity & Air flow :</i> Tiny glass bead thermistor.	
	<i>Air temperature :</i> Thermistor.	
	<i>Type K, Type J thermometer :</i> <i>Type K/J thermocouple probe.</i> <i>* Probes are optional.</i>	
Datalogger Sampling Time Setting range	Auto	1 second to 3600 seconds @ <i>Sampling time can set to 1 second, but memory data may loss.</i>
	Manual	Push the data logger button once will save data one time. @ <i>Set the sampling time to 0 second.</i> @ <i>Manual mode, can also select the 1 to 99 position (Location) no.</i>
Memory Card	SD memory card. 1 GB to 16 GB. <i>* It recommend use memory card \leq 4 GB.</i>	
Advanced setting	<ul style="list-style-type: none"> * Set clock time (Year/Month/Date, Hour/Minute/ Second) * Set sampling time * Auto power OFF management * Set beep Sound ON/OFF * Decimal point of SD card setting * SD memory card Format * Set thermometer type to Type K or Type J * Set temperature unit to $^{\circ}\text{C}$ or $^{\circ}\text{F}$ * Set air flow type (CFM/USA, CMM/EURO) * Set air flow area dimension 	
Temperature Compensation	Automatic temp. compensation for the Anemometer function and the type K/J thermometer.	
Data Hold	Freeze the display reading.	
Memory Recall	Maximum & Minimum value.	

Sampling Time of Display	Approx. 1 second.
Data Output	RS 232/USB PC computer interface. * <i>Connect the optional RS232 cable UPCB-02 will get the RS232 plug.</i> * <i>Connect the optional USB cable USB-01 will get the USB plug.</i>
Operating Temperature	0 to 50 °C.
Operating Humidity	Less than 85% R.H.
Power Supply	* <i>Alkaline or heavy duty DC 1.5 V battery (UM3, AA) x 6 PCs, or equivalent.</i>
	* <i>DC 9V adapter input. (AC/DC power adapter is optional).</i>
Power Current	Normal operation (w/o SD card save data and LCD Backlight is OFF) : <i>Approx. DC 30 mA.</i>
	When SD card save the data and LCD Backlight is OFF) : <i>Approx. DC 50 mA.</i>
Weight	347 g/ 0.76 LB. * <i>Meter only</i>
Dimension	<i>Main instrument :</i> 182 x 73 x 47.5 mm (7.1 x 2.9 x 1.9 inch)
	<i>Hot wire telescope probe :</i> Round, 12 mm Dia x 280 mm (min. length). Round, 12 mm Dia x 940 mm (max. length).
Accessories Included	* Instruction manual..... 1 PC * Hot wire telescope probe..... 1 PC * Hard carrying case 1 PC

Optional Accessories	<ul style="list-style-type: none"> * SD Card (2 G) * Type K thermocouple probes, refer to page 31. * AC to DC 9V adapter. * USB cable, USB-01. * RS232 cable, UPCB-02. * Data Acquisition software, SW-U801-WIN. * Excel Data Acquisition software, SW-E802
----------------------	--

2-2 Electrical Specifications (23±5 °C)

Air velocity

Measurement	Range	Resolution	Accuracy
m/s	0.2 to 5.0 m/s	0.01 m/s	±(5% + a) reading
	5.1 to 25.0 m/s	0.1 m/s	
Km/h	0.70 to 18.00 km/h	0.01 Km/h	or
	18.0 to 72.0 km/h	0.1 Km/h	
Mile/h (mph)	0.50 to 11.20 mph	0.01 mph	±(1% + a) full scale
	11.2 to 44.7 mph	0.1 mph	
Knot	0.40 to 9.70 knot	0.01 Knot	
	9.7 to 38.8 knot	0.1 Knot	
Ft/min	40-3940 ft/min	1 Ft/min	
@ a = 0.1 m/s, 0.3 km/h, 0.2 mile/h, 0.2 knot, 20 ft/min			
<p><i>Note:</i></p> <p>m/s - meters per second km/h - kilometers per hour</p> <p>ft/min - feet per minute knot - nautical miles per hour</p> <p>mile/h - miles per hour (international knot)</p>			

Air temperature

Measuring Range	0 °C to 50 °C/32 °F to 122 °F
Resolution	0.1 °C/0.1 °F
Accuracy	± 0.8 °C/1.5 °F

Air flow

<i>Measurement</i>	<i>Range</i>	<i>Resolution</i>
CMM (m ³ /min.)	0 to 54,000 CMM	0.001 to 1 CMM
CFM (ft ³ /min.)	0 to 1,907,000 CFM	0.001 to 100 CFM

<i>Measurement</i>	<i>Area</i>
CMM (m ³ /min.)	0.001 to 30.000 m ²
CFM (ft ³ /min.)	0.01 to 322.93 ft ²

Type K/J thermometer

<i>Sensor Type</i>	<i>Resolution</i>	<i>Range</i>	<i>Accuracy</i>
Type K	0.1 °C	-50.0 to 1300.0 °C -50.1 to -100.0 °C	± (0.4 % + 0.5 °C) ± (0.4 % + 1 °C)
	0.1 °F	-58.0 to 2372.0 °F -58.1 to -148.0 °F	± (0.4 % + 1 °F) ± (0.4 % + 1.8 °F)
Type J	0.1 °C	-50.0 to 1200.0 °C -50.1 to -100.0 °C	± (0.4 % + 0.5 °C) ± (0.4 % + 1 °C)
	0.1 °F	-58.0 to 2192.0 °F -58.1 to -148.0 °F	± (0.4 % + 1 °F) ± (0.4 % + 1.8 °F)

@ Above specification tests under the environment RF Field Strength less than 3 V/M & frequency less than 30 MHz only.

3. FRONT PANEL DESCRIPTION

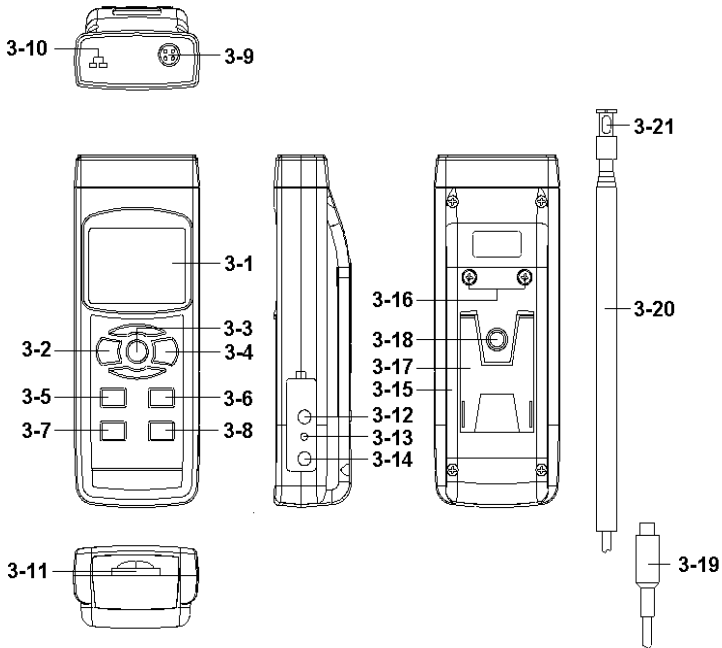

- 3-1 Display
- 3-2 Power Button (Backlight Button)
- 3-3 Hold Button
- 3-4 REC Button
- 3-5 UNIT Button (▲ Button)
- 3-6 FUNCTION Button (▼ Button)
- 3-7 SET Button (Time Button)
- 3-8 LOG Button (ENTER Button)
- 3-9 Probe input socket (Hot wire probe)
- 3-10 Type K/J thermometer socket
- 3-11 SD card socket

- 3-12 RS-232 Output Terminal
- 3-13 Reset Button
- 3-14 DC 9V Power Adapter Input Socket
- 3-15 Battery Compartment/Cover
- 3-16 Battery Cover Screws
- 3-17 Stand
- 3-18 Tripod Fix Nut
- 3-19 Probe Plug (Hot wire probe)
- 3-20 Telescope Probe (Hot wire probe)
- 3-21 Sensing Head (Hot wire probe)

4. MEASURING PROCEDURE

4-1 Function selection

1) Power on the meter by pressing the " Power button " (3-2, Fig. 1) > 1.5 seconds continuously.

* *After already power on the meter, pressing the " Power button " > 1.5 seconds continuously will turn off the meter.*

2) The meter can select 6 kind function as :

1. **Air velocity/Temp.**
2. **Air flow (CFM/USA type, CMM/Euro type)**
3. **Type K/J Thermometer**

Pressing the " Function Button " (3-6, Fig. 1) continuously (not release the button), the Display will show the following text in sequence :

Air	Air velocity/Temp. measurement
AirF	Air flow measurement
tP	Type K/J Thermometer measurement

Until the Display show the desired mode (Function), just release the " Function Button " (3-6, Fig. 1), the meter will execute this function with default.

4-2 Air velocity/Temp. measurement

1) Important information of using the Telescope Probe

* When the probe is not used, the " Sensor cover " should slide to the up position.

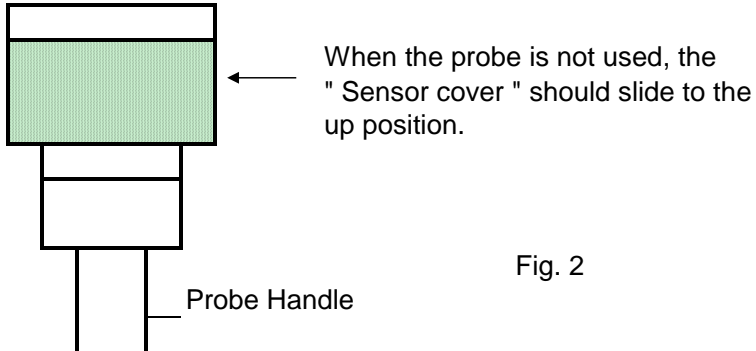

* When begin to use the probe,
a. Slide the sensor cover to the down position, let the air velocity sensor to contact the air, refer Fig. 3.
b. Extent the telescope probe to the convenient length ,refer to Fig. 3

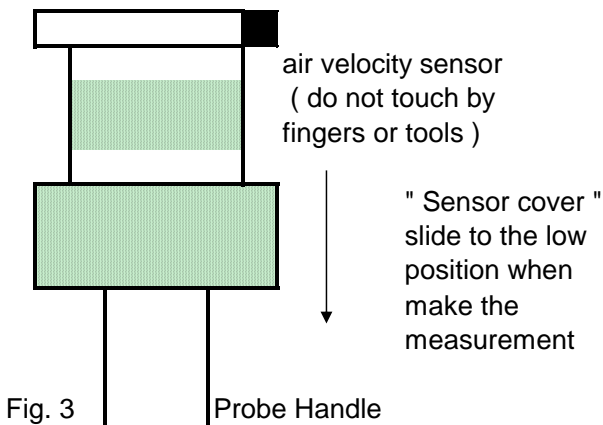

* Do not use the fingers or any tools to touch the air velocity sensor, otherwise the meter may happen the permanent damage without warranty.

* Direction of the sensor head :
There is a mark on the top of the " Sensor Head ",
When make the measurement, then this mark should
against the measured wind, refer Fig. 4.

When sensor head face against the measurement air,
then the upper display will show the air velocity value.
The lower display will show the temperature value.

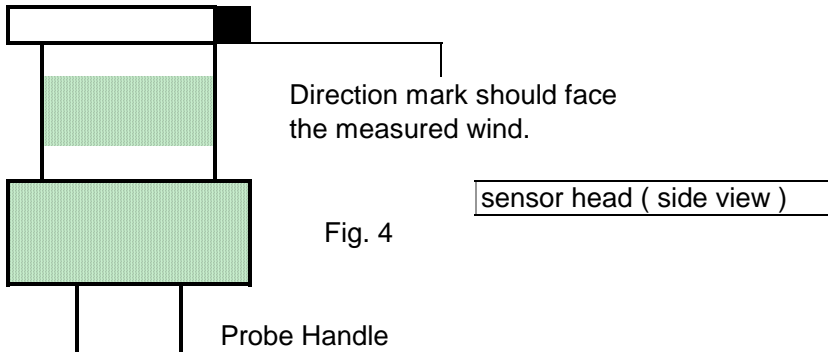

- 2) Function select to " Air velocity/Temp. " measurement.
- 3). Plug the " Probe Plug " (3-19, Fig. 1) into the " Probe Input Socket " (3-9, Fig. 1).
Power on the meter by pressing the " Power Button " (3-2, Fig. 1) > 1.5 seconds continuously.
- 4) Hold the " Telescope Probe " (3-20, Fig. 1) by hand and let the " Sensing Head " (3-21, Fig. 1) face against the measuring air flow source, then the Display (3-1, Fig. 1) will show air velocity directly. At the same time, the lower Display will show the air temperature value.

Measuring Consideration :

The mark on the sensor head indicates the direction that " need to face against the air flow.

Change the Air velocity unit

Air velocity unit are :

m/s, Km/h, mph (Mile/h), Knots, FPM (Ft/min)

If intend to change the Air velocity unit, press the Unit Button " (3-5, Fig. 1) > 1.5 seconds, the unit will change from m/s to Km/h, mph, Knot, FPM in sequence, until the desired unit is present on the Display release the " Unit Button ", the select unit will save into the memory with default.

Change the temperature unit (°C, °F)

The meter Temp. display unit is defaulted to " °C ". If intend to let the meter's temperature unit default to " °F " , then please refer chapter 7-7, page 26.

4-3 Air flow measurement.

- a. Function select to " Air flow " , refer to page 10.

AirF/USA : Air flow in CFM unit

or

AirF/Euro : Air flow in CMM unit

Remark :

- a. *How to select the CFM air flow or CMM air flow, details please reefer to Chapter 7-9, page 24.*
- b. *Set air flow area dimension (ft² or meter²) at the first, details please refer to Chapter 7-10, page 25.*
- c. *Other procedures same as " Air velocity/Temp. measurement " , refer to page 11.*

4-4 Type K/J thermometer

- a. Function select to " Type K/J thermometer ", refer to page 10.
- b. Plug the Thermocouple Temp. Probe (Type K Temp. probe or Type J Temp. probe, optional) into " Type K/J Probe Input Socket " (3-10, Fig. 1)
The Display will show the measuring value that sensing from the Temp. probe.
- c. If the Display show the indicator " K ", it is ready for Type K thermometer.
If the Display show the indicator " J ", it is ready for Type J thermometer.

Remark :

*The meter is defaulted to " Type K thermometer ".
If intend to select the " Type J thermometer with default , please refer chapter 7-8, page 24.*

4-5 Data Hold

During the measurement, press the " Hold Button " (3-3, Fig. 1) once will hold the measured value & the LCD will display a " HOLD " symbol.

Press the " Hold Button " once again will release the data hold function.

4-6 Data Record (Max., Min. reading)

- 1) The data record function records the maximum and minimum readings. Press the " REC Button " (3-4, Fig. 1) once to start the Data Record function and there will be a " REC " symbol on the display.
- 2) With the " REC " symbol on the display :
 - a) Press the " REC Button " (3-4, Fig. 1) once, the " REC MAX " symbol along with the maximum value will appear on the display.
 - b) Press the " REC Button " (3-4, Fig. 1) again, the " REC MIN " symbol along with the minimum value will appear on the display.

- c) Press the " REC Button " (3-4, Fig. 1) again, the " MIN " symbol will be appeared, LCD only show the " REC " symbol, the meter start the Data Record function again.
- 3) To exit the memory record function, just press the " REC Button " (3-4, Fig. 1) > 1.5 seconds continuously. The display will revert to the current reading.

4-7 LCD Backlight ON/OFF

- 1) After power ON, the " LCD Backlight " will light automatically. During the measurement, press the " Backlight Button " (3-2, Fig. 1) once will turn OFF the " LCD Backlight " .
- 2) Press the " Backlight Button " once again will turn ON the " LCD Backlight " again.

5. DATALOGGER

5-1 Preparation before execute datalogger function

a. Insert the SD card

Prepare a " SD memory card " (1 G to 16 G, optional),

** It recommend use memory card ≤ 4 GB.*

insert the SD card into the " SD card socket " (3-11, Fig. 1).

The front panel of the SD card should face against the the down case.

If SD card just the first time use into the meter, it recommend to make the " SD card Format " at first. , please refer chapter 7-6, page 23.

** It recommend strongly, do not use memory cards that have been formatted by other meter or by a computer. Reformat the memory card with your meter.*

c. Time setting

If the meter is used at first time, it should to adjust the clock time exactly, please refer chapter 7-1 (page 20).

d. Decimal format setting

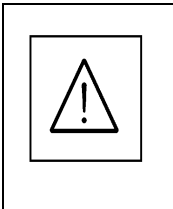

The numerical data structure of SD card is default used the " . " as the decimal, for example "20.6" "1000.53" . But in certain countries (Europe ...) is used the " , " as the decimal point, for example " 20, 6 " "1000,53". Under such situation, it should change the Decimal character at first, details of setting the Decimal point, refer to Chapter 7-5, page 22.

5-2 Auto Datalogger (Set sampling time ≥ 1 second)

a. Start the datalogger

Press the " LOG Button (3-8, Fig. 1) > 1.5 seconds continuously, the lower LCD will show the text of " Log " (or show " Log " with the Temp. value alternately),

then " REC " symbol will flashing per sampling time, at the same time the measuring data along the time information will be saved into the memory circuit.

Remark :

- * *How to set the sampling time, refer to Chapter 7-2, page 21.*
- * *How to set the beeper sound is enable, refer to Chapter 7-4, page 22.*

b. Pause the datalogger

During execute the Datalogger function, if press the " LOG Button " (3-8, Fig. 1) once will pause the Datalogger function (stop to save the measuring data into the memory circuit temporally). In the same time the " REC " symbol will stop flashing, the lower LCD will show the text of " Log " (or show " Log " with the Temp. value alternately).

Remark :

If press the " LOG Button " (3-8, Fig. 1) once again will execute the Datalogger again, the " REC " symbol will flashing.

c. Finish the Datalogger

During execute the Datalogger function, press the " LOG Button (3-8, Fig. 1) > 1.5 seconds continuously again will finish the Datalooger function, the " Log " text will be disappeared and finish the Datalogger. function.

5-3 Manual Datalogger (Set sampling time = 0 second)

a. Set sampling time is to 0 second

Press the " LOG Button (3-8, Fig. 1) > 1.5 second , the lower LCD will show the " Position no. " (or show the Position no. with the Temp. value alternately), then press the " LOG Button " (3-8, Fig. 1) once, the " REC " symbol will flashing once and Beeper will sound once, at the same time the measuring data along the time information will be saved into the memory circuit.

Remark :

During execute the Manual Datalogger, it can use the " ▲ Button " (3-5, Fig. 1) or " ▼ Button " (3-6, Fig. 1) to set the measuring position (1 to 99, for example room 1 to room 99) to identify the measurement location , the lower Display will show P x (x = 1 to 99).

b. Finish the Datalogger

During execute the Datalogger function, press the " LOG Button (3-8, Fig. 1) > 1.5 seconds continuously again will finish the Datalogger function, the Position no. " PXX " will be disappeared and finish the Datalogger. function.

5-4 Check time information

During the normal measurement (not execute the Datalogger), If press " Clock Button " (3-7, Fig. 1) once , the lower LCD display will present the time information of Year/Month, Date/Hour, Minute/Second and the Sampling time information in sequence.

5-5 SD Card Data structure

- 1) When the first time, the SD card is used into the meter, the SD card will generate a folder :

AHB01

- 2) If the first time to execute the Datalogger, under the route AHB01\, will generate a new file name AHB01001.XLS.
After exist the Datalogger, then execute again, the data will save to the AHB01001.XLS until Data column reach to 30,000 columns, then will generate a new file, for example AHB01002.XLS
- 3) Under the folder AHB01\, if the total files more than 99 files, will generate anew route, such as AHB02\
- 4) The file's route structure :

AHB01\

AHB01001.XLS

AHB01002.XLS

.....

AHB01099.XLS

AHB02\

AHB02001.XLS

AHB02002.XLS

.....

AHB02099.XLS

AHBXX\

.....

Remark : XX - Max. value is 10.

6. Saving data from the SD card to the computer (EXCEL software)

- 1) After execute the Data Logger function, take away the SD card out from the " SD card socket " (3-11, Fig. 1).
- 2) Plug in the SD card into the Computer's SD card slot (if your computer build in this installation) or insert the SD card into the " SD card adapter ". then connect the " SD card adapter " into the computer.
- 3) Power ON the computer and run the " EXCEL software ". Down load the saving data file (for example the file name : AHB01001.XLS, AHB01002.XLS) from the SD card to the computer. The saving data will present into the EXCEL software screen (for example as following EXCEL data screens) , then user can use those EXCEL data to make the further Data or Graphic analysis usefully.

EXCEL data screen (for example)

	A	B	C	D	E	F	G	H
1	Place	Date	Time	Value	Unit	Value	Unit	
2	2	2000/1/1	00:04:20	0	m/S	28.1	AMTemp C	
3	3	2000/1/1	00:04:21	0	m/S	28.1	AMTemp C	
4	4	2000/1/1	00:04:23	0	m/S	28.2	AMTemp C	
5	5	2000/1/1	00:04:25	0	m/S	28.2	AMTemp C	
6	6	2000/1/1	00:04:27	0	m/S	28.2	AMTemp C	
7	7	2000/1/1	00:04:29	0	m/S	28.2	AMTemp C	
8	8	2000/1/1	00:04:31	0	m/S	28.2	AMTemp C	
9	9	2000/1/1	00:04:33	0.04	m/S	28.2	AMTemp C	
10	10	2000/1/1	00:04:35	0.26	m/S	28.2	AMTemp C	
11	11	2000/1/1	00:04:37	0.45	m/S	28.3	AMTemp C	
12	12	2000/1/1	00:04:39	0.62	m/S	28.4	AMTemp C	
13	13	2000/1/1	00:04:41	0.6	m/S	28.4	AMTemp C	
14	14	2000/1/1	00:04:43	0.64	m/S	28.4	AMTemp C	
15	15	2000/1/1	00:04:45	1.02	m/S	28.4	AMTemp C	
16	16	2000/1/1	00:04:47	2.13	m/S	28.3	AMTemp C	
17	17	2000/1/1	00:04:49	3.54	m/S	28.1	AMTemp C	
18	18	2000/1/1	00:04:51	4.16	m/S	28	AMTemp C	
19	19	2000/1/1	00:04:53	4.13	m/S	28	AMTemp C	
20	20	2000/1/1	00:04:55	4.02	m/S	28	AMTemp C	
21	21	2000/1/1	00:04:57	3.35	m/S	28.1	AMTemp C	
22	22	2000/1/1	00:04:59	2.58	m/S	28.1	AMTemp C	
23	23	2000/1/1	00:05:01	1.99	m/S	28	AMTemp C	
24	24	2000/1/1	00:05:03	1.98	m/S	28	AMTemp C	
25	25	2000/1/1	00:05:05	2.43	m/S	28	AMTemp C	

EXCEL graphic screen (for example)

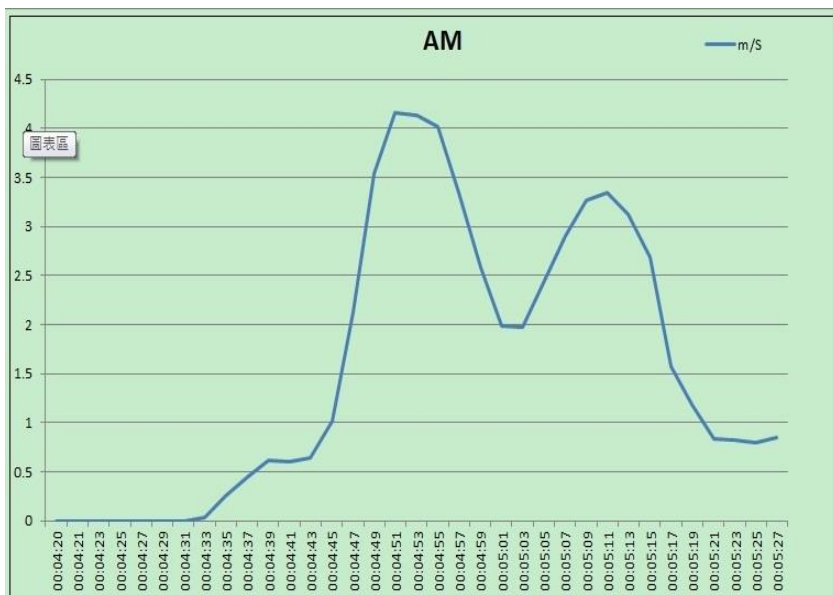

7. ADVANCED SETTING

Under do not execute the Datalogger function, press the " SET Button " (3-7, Fig. 1) continuously at least two seconds will enter the " Advanced Setting " mode. then press the " SET Button " (3-7, Fig. 1) once a while in sequence to select the ten main function, the lower display will show :

- dAtE.....** Set clock time (Year/Month/Date, Hour/Minute/ Second)
- SP-t.....** Set sampling time (Hour/Minute/Second)
- PoFF.....** Auto power OFF management
- bEEP.....** Set beeper sound ON/OFF
- dEC.....** Set SD card Decimal character
- Sd F.....** SD memory card Format
- tYPE.....** Select the Thermometer to Type K or Type J
- AirF....** Select the Air flow unit to CMM or CFM.
- ArEA....** Set the area size of Air flow measurement
- t-CF.....** Select the Temp. unit to °C or °F

Remark :

During execute the " Advanced Setting " function, if press " SET Button " (3-7, Fig. 1) > 1.5 seconds will exit the " Advanced Setting " function, the LCD will return to normal screen.

7-1 Set clock time (Year/Month/Date, Hour/Minute/ Second)

When the lower display show " dAtE "

- 1) Use the " ▲ Button " (3-5, Fig. 1) or " ▼ Button " (3-6, Fig. 1) to adjust the value (Setting start from Year value). After the desired value is set, press the " Enter Button " (3-8, Fig. 1) once will going to next value adjustment (for example, first setting

value is Year then next to adjust Month, Date, Hour, Minute, Second value).

Remark :

The adjusted value will be flashed.

- 2) After set all the time value (Year, Month, Date, Hour, Minute, Second), press the " ENETER Button " (3-8, Fig. 1) once will save the time value.

Remark :

After the time value is setting, the internal clock will run precisely even Power off if the battery is under normal condition (No low battery power).

7-2 Set sampling time (seconds)

When the lower display show " SP-t "

- 1) Use the " ▲ Button " (3-5, Fig. 1) or " ▼ Button " (3-6, Fig. 1) to adjust the value (0, 1, 2, 5, 10, 30,60, 120, 300, 600, 1800,3600 seconds).
- 2) After the Sampling value is selected, press the " Enter Button " (3-8, Fig. 1) will save the setting function with default.

7-3 Auto power OFF management

When the lower display show " PoFF "

- 1) Use the " ▲ Button " (3-5, Fig. 1) or " ▼ Button " (3-6, Fig. 1) to select the upper value to " yES " or " no ".

yES - Auto Power Off management will enable.

no - Auto Power Off management will disable.

- 2) After select the upper text to " yES " or " no ", press the " ENTER Button " (3-8, Fig. 1) will save the setting function with default.

7-4 Set beeper sound ON/OFF

When the lower display show " bEEP "

- 1) Use the " ▲ Button " (3-5, Fig. 1) or " ▼ Button " (3-6, Fig. 1) to select the upper value to " yES " or " no ".

yES - Meter's beep sound will be ON with default.

no - Meter's beep sound will be OFF with default.

- 2) After select the upper text to " yES " or " no ", press the " ENTER Button " (3-8, Fig. 1) will save the setting function with default.

7-5 Decimal point of SD card setting

The numerical data structure of SD card is default used the "." as the decimal, for example "20.6" "1000.53". But in certain countries (Europe ...) is used the ",", as the decimal point, for example " 20,6 " "1000,53". Under such situation, it should change the Decimal character at first.

When the lower display show " dEC "

- 1) Use the " ▲ Button " (3-5, Fig. 1) or " ▼ Button " (3-6, Fig. 1) to select the upper text to " USA " or " Euro ".

USA - Use "." as the Decimal point with default.

Euro - Use ",", as the Decimal point with default.

- 2) After select the upper text to " USA " or " Euro ", press the " ENTER Button " (3-8, Fig. 1) will save the setting function with default.

7-6 SD memory card Format

When the lower display show " Sd F "

- 1) Use the " ▲ Button " (3-5, Fig. 1) or " ▼ Button " (3-6, Fig. 1) to select the upper value to " yES " or " no ".

yES - Intend to format the SD memory card

no - Not execute the SD memory card format

- 2) If select the upper to " yES ", press the " Enter Button " (3-8, Fig. 1) once again, the Display will show text " yES Enter " to confirm again, if make sure to do the SD memory card format, then press " Enter Button " once will format the SD memory clear all the existing data that already saving into the SD card.

7-7 Select the Temp. unit to $^{\circ}\text{C}$ or $^{\circ}\text{F}$

When the lower display show " t-CF "

- 1) Use the " ▲ Button " (3-5, Fig. 1) or " ▼ Button " (3-6, Fig. 1) to select the upper Display text to " C " or " F ".

C - Temperature unit is $^{\circ}\text{C}$

F - Temperature unit is $^{\circ}\text{F}$

- 2) After Display unit is selected to " C " or " F ", press the " Enter Button " (3-8, Fig. 1) will save the setting function with default.

7-8 Select the Thermometer to Type K or Type J

When the lower display show " tYPE "

- 1) Use the " ▲ Button " (3-5, Fig. 1) or " ▼ Button " (3-6, Fig. 1) to select the Display unit to " K " or " J "

K - Type K thermometer

j - Type J thermometer

- 2) After Display unit is selected to " K " or " J ", press the " Enter Button " (3-8, Fig. 1) will save the setting function with default.

7-9 Select the Air flow unit to CMM or CFM.

When the lower display show " AirF "

- 1) Use the " ▲ Button " (3-5, Fig. 1) or " ▼ Button " (3-6, Fig. 1) to select the upper Display text to " Euro " or " USA "

Euro - Air flow measurement in the CMM unit

USA - Air flow measurement in the CFM unit

CFM : Cube feet per minute

CMM : Cube feet per minute

- 2) After lower Display text is selected to " Euro " or " USA ", press the " Enter Button " (3-8, Fig. 1) will save the setting function with default.

7-10 Set the area size of Air flow measurement

When the lower display show " ArEA "

- 1) Use the " ▲ Button " (3-5, Fig. 1) or " ▼ Button " (3-6, Fig. 1) to select the lower Display text to " ArEA/Euro " or " ArEA/USA "

ArEA/Euro - Area size of Air flow (CMM) setting is in " Square meters (meters ^ 2) " unit.

ArEA/USA - Area size of Air flow (CFM) setting is in " Square feet (feet ^ 2)" unit

- 2) After lower Display text is selected to " ArEA/Euro " or " ArEA/USA ", press the " Enter Button " (3-8, Fig. 1) will save the setting function with default.

8. POWER SUPPLY from DC ADAPTER

The meter also can supply the power supply from the DC 9V Power Adapter (optional). Insert the plug of Power Adapter into " DC 9V Power Adapter Input Socket " (3-14, Fig. 1). The meter will permanent power ON when use the DC ADAPTER power supply (The power Button function is disable).

9. BATTERY REPLACEMENT

- 1) When the left corner of LCD display show " ", it is necessary to replace the battery. However, in-spec. measurement may still be made for several hours after low battery indicator appears before the instrument become inaccurate.
- 2) Loose the screws of the " Battery Cover screws " (3-16, Fig. 1) and take away the " Battery Cover " (3-15, Fig. 1) from the instrument and remove the battery.
- 3) Replace with DC 1.5 V battery (UM3, AA, Alkaline/heavy duty) x 6 PCs, and reinstate the cover.
- 4) Make sure the battery cover is secured after changing the battery.

10. SYSTEM RESET

If the meter happen the troubles such as :

CPU system is hold (for example, the key button can not be operated...).

Then make the system RESET will fix the problem.
The system RESET procedures will be either following method :

During the power on, use a pin to press the " Reset Button " (3-13, Fig. 1) once a while will reset the circuit system.

11. RS232 PC SERIAL INTERFACE

The instrument has RS232 PC serial interface via a 3.5 mm terminal (3-12, Fig. 1).

The data output is a 16 digit stream which can be utilized for user's specific application.

A RS232 lead with the following connection will be required to link the instrument with the PC serial port.

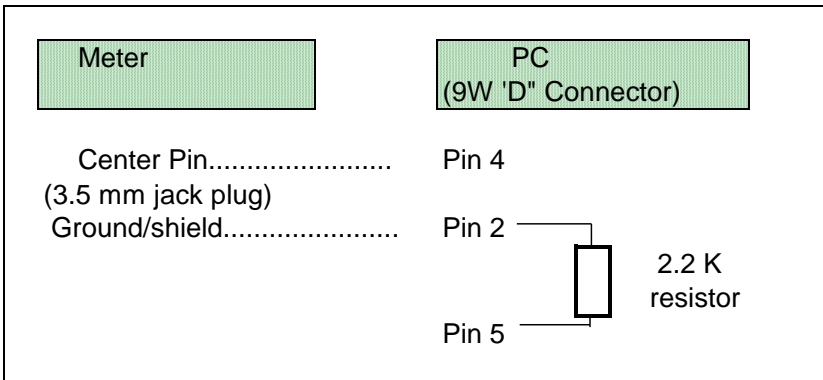

The 16 digits data stream will be displayed in the following format :

D15 D14 D13 D12 D11 D10 D9 D8 D7 D6 D5 D4 D3 D2 D1 D0

Each digit indicates the following status :

D0	End Word		
D1 & D8	Display reading, D1 = LSD, D8 = MSD For example : If the display reading is 1234, then D8 to D1 is : 00001234		
D9	Decimal Point(DP), position from right to the left 0 = No DP, 1= 1 DP, 2 = 2 DP, 3 = 3 DP		
D10	Polarity 0 = Positive 1 = Negative		
D11 & D12	Annunciator for Display		
	°C = 01	Knot = 09	mile/h = 12
	°F = 02	Km/h = 10	m/s = 08
	ft/min = 11		
D13	When send the upper display data = 1 When send the lower display data = 2		
D14	4		
D15	Start Word		

RS232 FORMAT : 9600, N, 8, 1

Baud rate	9600
Parity	No parity
Data bit no.	8 Data bits
Stop bit	1 Stop bit

(Type K) TP-01	<ul style="list-style-type: none"> * Max. short-tern operating Temperature: 300 °C (572 °F). * It is an ultra fast response naked-bead thermocouple suitable for many general purpose application.
Thermocouple Probe (Type K), TP-02A	<ul style="list-style-type: none"> * Measure Range: -50 °C to 900 °C , -58 °F to 1650 °F. * Dimension:12cm tube, 3.2mm Dia.
Thermocouple Probe (Type K), TP-03	<ul style="list-style-type: none"> * Measure Range: -50 °C to 1100 °C , -58 °F to 2012 °F. * Dimension: 13.6cm tube, 8mm Dia.
Surface Probe (Type K), TP-04	<ul style="list-style-type: none"> * Measure Range: -50 °C to 400 °C , -58 °F to 752 °F. * Size : Temp. sensing head - 15 mm Dia. Probe length - 120 mm.

13. PATENT

The meter (SD card structure) already get patent or patent pending in following countries :

Germany	Nr. 20 2008 016 337.4
JAPAN	3151214
TAIWAN	M 358970 M 359043
CHINA	ZL 2008 2 0189918.5 ZL 2008 2 0189917.0
USA	Patent pending

*SD card real time Data Recorder
+ Type K/J thermometer, Air flow*

HOT WIRE ANEMOMETER HUMIDITY/Temp.

Model : AM-4215SD



Your purchase of this HOT WIRE ANEMOMETER, HUMIDITY/Temp. meter with SD CARD DATA RECORDER marks a step forward for you into the field of precision measurement. Although this METER is a complex and delicate instrument, its durable structure developed. Please read the following instructions carefully and always keep this manual within easy reach.

OPERATION MANUAL