

Wind speed measurement, pocket type, IP-65

CUP ANEMOMETER

Model : AM-4220



Your purchase of this ANEMOMETER marks a step forward for you into the field of precision measurement.

Although this METER is a complex and delicate instrument, its durable structure will allow many years of use if proper operating techniques are developed. Please read the following instructions carefully and always keep this manual within easy reach.



OPERATION MANUAL

TABLE OF CONTENTS

1. FEATURES.....	1
2. SPECIFICATIONS.....	1
2-1 General Specifications.....	1
2-2 Electrical Specifications.....	2
3. FRONT PANEL DESCRIPTION.....	3
3-1 Cup Vane.....	3
3-2 Power (Logger ▲) Button.....	3
3-3 Hold (Unit ←)Button.....	3
3-4 REC (▼) Button.....	3
3-5 LCD Display.....	3
3-6 Battery Compartment/Cover.....	3
4. INSTALL THE VANE CUP.....	4
5. MEASURING PROCEDURE.....	5
5-1 Wind speed measurement.....	5
5-2 Unit change.....	5
5-3 Data Hold.....	6
5-4 Data Record (Max., Min. reading).....	6
6. DATA LOGGER.....	7
6-1 Save data.....	7
6-2 Call data.....	8
6-3 Delete data (Empty the memory).....	9
7. BATTERY REPLACEMENT.....	10

1. FEATURES

- * Cup vane anemometer, available for wind speed measurement, high reliability.
- * Measurement range : 0.9 to 35.0 m/s
- * Unit : m/s, km/h, ft/min, knot, mile/h.
- * LCD display.
- * IP 65, water resistance.
- * Microprocessor circuit ensures high accuracy and provides special functions and features.
- * Records Maximum and Minimum readings with recall.
- * 100 point data logger with recall.
- * Data hold.
- * Auto power off saves battery life.
- * Operates from DC 1.5V (UM4/AAA) x 4 PCs batteries.
- * Low-friction ball vane wheels is accurate in both high and low velocities.
- * Durable, long-lasting components, enclosed in strong, compact ABS-plastic housing.

2. SPECIFICATIONS

2-1 General Specifications

Display	LCD size : 28 mm x 19 mm.
Measurement Unit	m/S (meters per second) Km/h (kilometers per hour) Knot (nautical miles per hour) ft/min (feet per minute) mile/h (miles per hour)
Circuit	Custom one-chip of microprocessor LSI circuit.

Data Logger	Max. can save 100 point data with recall. Manual, push the data logger button once will save data one time.
Sensor Structure	Cup van probe with low friction ball bearing design.
Data Hold	Freeze the display reading.
Memory Recall	Maximum & Minimum value.
Sampling Time of display	Approx. 1 second.
Power off	Auto shut off saves battery life or manual off by push button.
Operating Temperature	0 to 50 °C.
Operating Humidity	Less than 80% R.H.
Power Supply	DC 1.5 V battery (UM4/AAA) x 4 PCs,
Power Current	Approx. DC 6.8 mA
Weight	181 g/ 0.4 LB. @ Battery is included.
Dimension	<i>Main instrument :</i> 190 x 40 x 32 mm (7.5" x 1.6" x 1.3")
	<i>Cup vane (3 cups with arm) :</i> 135 mm dia.
Accessories Included	Instruction manual.....1 PC Carrying case.....1 PC

2-2 Electrical Specifications (23± 5 °C)

<i>Measurement</i>	<i>Range</i>	<i>Resolution</i>	<i>Accuracy @ reading</i>
m/S	0.9 - 35.0 m/S	0.1 m/S	± (2%+0.2 m/S)
Km/h	2.5 - 126.0 Km/h	0.1 Km/h	± (2%+0.8 Km/h)
Knot	1.4 - 68.0 Knots	0.1 Knots	± (2%+0.4 Knots)
Ft/min	144 - 6895 Ft/min	1 Ft/min	± (2%+40 Ft/min)
Mile/h	1.6 - 78.2 Mile/h	0.1 Mile/h	± (2%+0.4 Mile/h)

3. FRONT PANEL DESCRIPTION

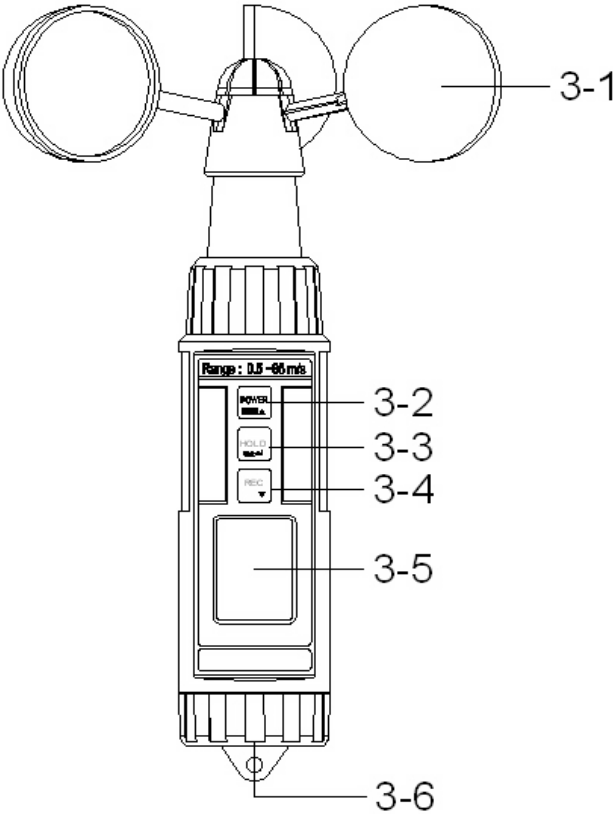

- 3-1 Cup Vane
- 3-2 Power (Logger ▲) Button
- 3-3 Hold (Unit ←) Button
- 3-4 REC (▼) Button
- 3-5 LCD Display
- 3-6 Battery Compartment/Cover

4. INSTALL THE VANE CUP

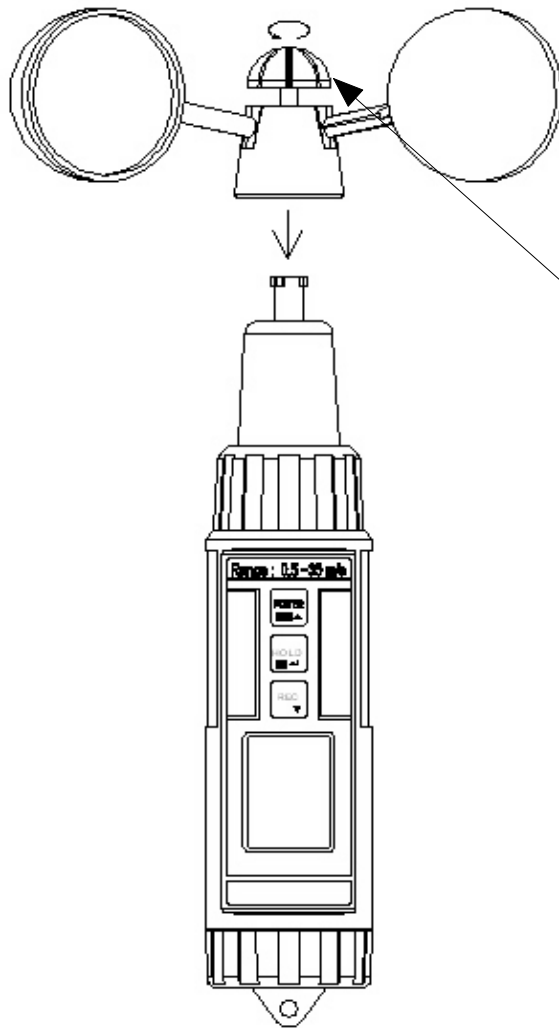

Rotate the top screw in counter clockwise direction until the screw is secured.

5. MEASURING PROCEDURE

5-1 Wind speed measurement

1) Turn on the meter by pressing the " Power Button " (3-2, Fig. 1) momentarily.

** Pressing the " Power Button " (3-2, Fig. 1) momentarily again will turn off the meter.*

2) Uses the hand to hold the meter vertically.

The " Cup Vane " (3-1) will be rotated, shows the measured the wind speed value on the " LCD Display " (3-5, Fig. 1).

5-2 Unit change

1) Meter defaults unit value is " m/s ".

Meter unit value can be changed to " m/s, km/h, knot, ft/min, mile/h "

2) The method to change the unit :

Press the " Unit Button " (3-3, Fig. 1) continuously, after several seconds the unit will change from m/s, km/h, knot, ft/min, mile/h " in sequence. Until reach the desired unit, release the finger from the " Unit Button " (3-3, Fig. 1), new unit will saving into the memory circuit no matter the meter is turned off.

** When the display shows " HOLD " (refer 5-3) or " REC " (refer 5-4), it can not change the unit.*

5-3 Data Hold

- * During the measurement, press the " Hold Button " (3-3, Fig. 1) momentarily to hold the measured value. The LCD will show a " HOLD " symbol.
- * Press the " Hold Button " once again to release the data hold function.

5-4 Data Record (Max., Min. reading)

- 1) The data record function records the maximum and minimum readings. Press the " REC Button " (3-4, Fig. 1) momentarily to start the Data Record function, shows " REC " on the display.
- 2) With the " REC " symbol on the display.
 - a) Press the " REC Button " (3-4, Fig. 1) momentarily, the " REC MAX " symbol along with the maximum value will appear on the display.
 - b) Press the " REC Button " (3-4, Fig. 1) momentarily again, the " REC MIN " symbol along with the minimum value will appear on the display.

** When display shows " REC MAX " or " REC MIN ", press the " Hold Button " (3-3, Fig. 1) momentarily will delete the max. (min.) value, the display will show the " REC. " only and execute the memory function continuously.*

- c) To exit the memory record function, press the " REC " button for 2 seconds at least. The display will revert to the current reading, not show " REC "

6. DATA LOGGER

The meter can save max. 100 point data into the the memory circuit

6-1 Save data

- 1) Turn on the meter.
- 2) Press the " REC Button " (3-4, Fig. 1) momentarily, shows " REC " on the display.
- 3) Press the " Logger Button " (3-2, Fig. 1) momentarily will save one measuring value to memory, display will show :

Example :

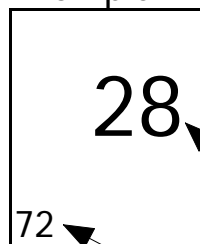

a. The memory position that save the recent data.

b. The memory left space no.

$$c. a + b = 100$$

$$\text{For example : } 28 + 72 = 100$$

- 4) To exit the memory data logger (record) function, press the " REC " button for 2 seconds at least. The display will revert to the current reading, not show " REC

6-2 Call data

1) Turn on the meter.

Press the " Hold Button " (3-3, Fig. 1) momentarily, LCD shows " HOLD ".

Following, press the " REC Button " (3-4, Fig. 1) momentarily, display shows :

Example :

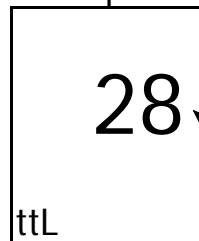

The total data point that are saved into the memory.

2) Uses " ▲ Button " (3-2, Fig. 1) or " ▼ Button " (3-4, Fig. 1) to call the data that already saved into the memory.

Note :

** During call the data, the unit display will be flashed.*

Example :

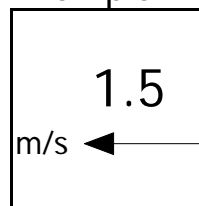

flashing

* Press " Hold Button " (3-3. Fig. 1) will exit the data call function.

6-3 Delete data (Empty the memory)

- 1) Turn off the meter first.
- 2) Press the " REC Button " (3-4, Fig. 1) continuously and not release, at the same time press the " Power Button " (3-2, Fig. 1) momentarily, the display will show following screen, then release both fingers from the buttons.

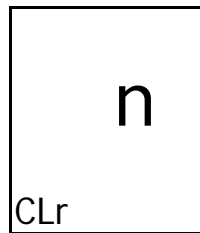

- 3) Press " ▼ Button " momentarily, display shows :

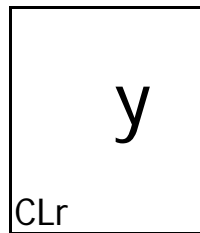

- 4) Press " ← Button " (3-3. Fig. 1) momentarily, the display shows :

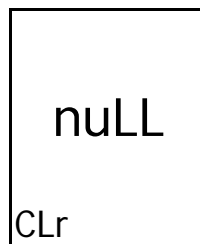

Now all the saved data is deleted, memory will empty.

7. BATTERY REPLACEMENT

- * Replace the batteries when the left corner of the LCD displays the low battery icon "  ", using 4 fresh 1.5 V (UM4, AAA) batteries.
- * To change the batteries, open (rotate clockwise direction) the " Battery Cover " (3-6, Fig. 1).
- * Make sure the " Battery cover " (3-6, Fig 1) is secured after changing the batteries.